



Information and Entertainment System

Special Tool(s)

 ST1137-A	73III Automotive Meter 105-R0057 or equivalent
 ST2834-A	Vehicle Communication Module (VCM) and Integrated Diagnostic System (IDS) software with appropriate hardware, or equivalent scan tool
 ST2574-A	Flex Probe Kit 105-R025C or equivalent

Principles of Operation

NOTE: The Smart Junction Box (SJB) is also known as the Generic Electronic Module (GEM).

Audio Control Module (ACM)

The audio system can be powered up when the ignition is in the ON or ACC position. When on, the Audio Control Module (ACM) directs audio signals to the speakers through separate positive and negative circuits for each of the audio channels. The [ACM](#) provides internal circuit protection for shorts to ground, shorts to voltage, or shorts between any output circuits.

Noise Suppression Equipment

The radio interference suppression equipment reduces interference transmitted through the speakers by the engine ignition and electrical systems.

Antenna

The antenna is a fixed mast antenna mounted on the exterior of the vehicle. The antenna receives both AM and FM radio waves. The audio signals are then sent to the [ACM](#) through the antenna cables.

Subwoofers

The subwoofer speakers on the 500-watt system are located in the front doors and are powered by individual amplifiers located on each speaker. In addition to these subwoofer speakers, the 1000-watt system includes an enclosure with 2 subwoofer speakers powered by 2 amplifiers, each. The enable/clip circuit carries out 2 functions: to turn on the subwoofer amplifier, and to monitor an overload condition to the subwoofer amplifier. In the event of an overload, the [ACM](#) clips the audio output signal to the subwoofer amplifier (heard as distortion).

Satellite Audio

The satellite audio system consists of the Satellite Digital Audio Receiver System (SDARS) module, a satellite radio antenna, and antenna cable (part of the decklid harness). The satellite radio antenna receives digital audio signals and sends them to the [SDARS](#) module, where the signals are converted to analog and sent to the [ACM](#). The wake-up signal for the [SDARS](#) module is sent from the [ACM](#) through the Medium Speed Controller Area Network (MS-CAN).

Audio Input Jack

The audio input jack allows for a portable MP3 player to be connected to the vehicle audio system. When a portable MP3 player is connected, audio from the MP3 player can be played through the vehicle speakers.

Navigation

The navigation module is integrated in the [ACM](#) and controls the operation and the interface between the user, the vehicle subsystems, and the external components. The navigation module communicates with other vehicle systems via the [MS-CAN](#) and can be diagnosed with a scan tool.

The vehicle navigation system guides the user to a pre-entered destination. A navigation map DVD stored in the navigation module sends route calculation data to the [ACM](#). The [ACM](#) audibly and visually instructs the user of the maneuvers required to arrive at the destination entered.

In order to calculate the initial vehicle position, the Global Positioning System (GPS) antenna is used to track several available satellites simultaneously. The [GPS](#) antenna only receives data and does not communicate with the satellites. A gyroscope, integral to the navigation module, monitors the pitch and yaw of the vehicle created during cornering or turning. Vehicle speed and reverse signals received through the [MS-CAN](#) are also used to detect vehicle speed and direction changes.

Network Communication

The following audio system components communicate via the [MS-CAN](#) :

- [ACM](#)
- Navigation [ACM](#)
- [SDARS](#) module

The following messages are utilized by the audio system:

Message	Transmitting Module	Receiving Module(s)	Audio System Function
Ignition Switch Position	Smart Junction Box (SJB)	ACM SDARS module	Indicates ignition switch position for power-up/shut-down.
Illumination Dimmer Level	SJB	ACM	Controls the backlight intensity, based on the position of the dimmer switch.
Transmission Selector (PRNDL) Range	Instrument Cluster (IC)	ACM	For navigation system, this signal is used for more accurate navigation tracking.
Vehicle Speed	IC	ACM	Used by the ACM for the speed-compensated volume function.
Navigation Radio Rolling Wheel Count	IC	ACM	For navigation system, this signal is used for more accurate navigation tracking.

Inspection and Verification

1. Verify the customer concern.

2. Visually inspect for obvious signs of mechanical or electrical damage.

Visual Inspection Chart

Mechanical	Electrical
<ul style="list-style-type: none"> • Audio Control Module (ACM) • Antenna or antenna cable(s) • Global Positioning System (GPS) antenna • Navigation map DVD • Satellite radio antenna • Speaker mounting/speaker cones • Radio ignition interference capacitors, radio frequency interference suppression bond, and radio receiver hood bonding strap 	<ul style="list-style-type: none"> • Smart Junction Box (SJB) fuse (s): <ul style="list-style-type: none"> ▪ 6 (5A) (ACM) ▪ 20 (10A) (ACM) • Bussed Electrical Center (BEC) fuse(s): <ul style="list-style-type: none"> ▪ 6 (30A) (luggage compartment amplifiers) ▪ 9 (30A) (luggage compartment amplifiers) ▪ 16 (30A) (door amplifiers) ▪ 56 (20A) (ACM, SDARS module) • Wiring, terminals or connectors

3. If an obvious cause for an observed or reported concern is found, correct the cause (if possible) before proceeding to the next step.

4. **NOTE:** Make sure to use the latest scan tool software release.

If the cause is not visually evident, connect the scan tool to the Data Link Connector (DLC).

5. **NOTE:** The Vehicle Communication Module (VCM) LED prove-out confirms power and ground from the [DLC](#) are provided to the [VCM](#).

If the scan tool does not communicate with the [VCM](#):

- Check the [VCM](#) connection to the vehicle.
- Check the scan tool connection to the [VCM](#).
- Refer to [Section 418-00](#), No Power To The Scan Tool, to diagnose no communication with the scan tool.

6. If the scan tool does not communicate with the vehicle:
 - Verify the ignition key is in the ON position.
 - Verify the scan tool operation with a known good vehicle.
 - Refer to [Section 418-00](#) to diagnose no response from the PCM.
7. Carry out the network test.
 - If the scan tool responds with no communication for one or more modules, refer to [Section 418-00](#).
 - If the network test passes, retrieve and record the continuous memory DTCs.
8. If the DTCs retrieved are related to the concern, go to DTC Charts in this section.
9. If no DTCs related to the concern are retrieved, go to the Speaker Walk-Around Test, the Audio Control Module (ACM) Self-Diagnostic Mode — Without Navigation, the Audio Control Module (ACM) Self-Diagnostic Mode — Navigation, or the Satellite Audio Bezel Diagnostic Test.

Speaker Walk-Around Test

NOTE: To enter the speaker walk-around test or [ACM](#) self-diagnostic mode, the audio system must be on and in radio tuner (AM/FM) mode.

1. To enter the speaker walk-around test, simultaneously press and hold the preset buttons 3 and 6.

2. The speaker walk-around test stops at each speaker and applies sound to each speaker for about 1-2 seconds. Each speaker is tested and displayed on the [ACM](#) in the following sequence: RF, LF, LR, RR, and SUBWOOFER.
3. To exit the speaker walk-around test, turn the key to OFF, turn the audio system off, or press preset button 1 for diagnostics.

Audio Control Module (ACM) Self-Diagnostic Mode — Without Navigation

NOTE: To enter the [ACM](#) self-diagnostic mode, the audio system must be on and in radio tuner (AM/FM) mode.

1. To enter the following tests, press the desired preset button while in the speaker walk-around test.
2. The self-diagnostic mode has the following functions available:
 - Preset button 1 = On-Demand Self-Test. This button runs the on-demand self-test.
 - Pressing the MENU DOWN button allows scrolling of any DTCs found during the test while in this menu.
 - Preset button 2 = Display Continuous DTCs. This button enables viewing of any continuous DTCs that have been logged.
 - Pressing the MENU UP button allows scrolling of any DTCs while in this menu.
 - While continuous DTCs are being displayed, pressing the EJECT button will clear all present DTCs. The key must be cycled OFF, then ON, to permanently clear DTCs.
 - Preset button 3 = Signal Strength Test. This button displays the signal strength.
 - Preset button 4 = Software Version Display. This button displays the [ACM](#) software version.
 - Pressing the MENU UP button allows scrolling of all audio subsystem software versions while in this menu.
 - Preset button 5 = Display Test. This test illuminates all the display segments for 5 seconds, then either turns all segments off or indicates DISPLAY TEST on the screen.
 - Preset button 6 = Configuration Status. This button enables [ACM](#) configuration status.
 - Pressing the MENU UP button displays the [ACM](#) part number while in this menu.
3. To exit the self-diagnostic mode, turn the key to OFF or turn the audio system off.
4. If the concern remains and the fault is not detected, GO to [Symptom Chart - Audio System](#).

Audio Control Module (ACM) Self-Diagnostic Mode — Navigation

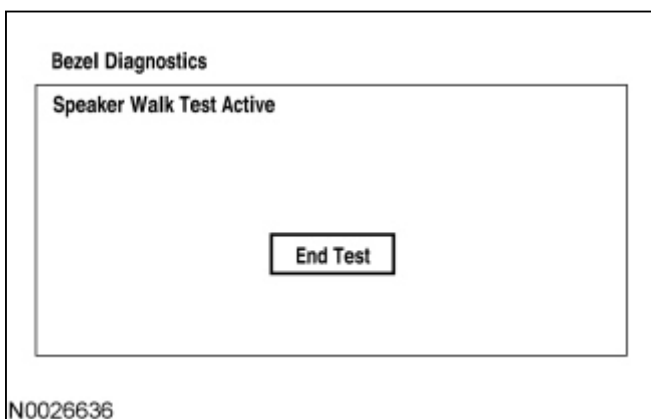

1. To enter the self-diagnostic mode, press "End Test" during the speaker walk-around test.

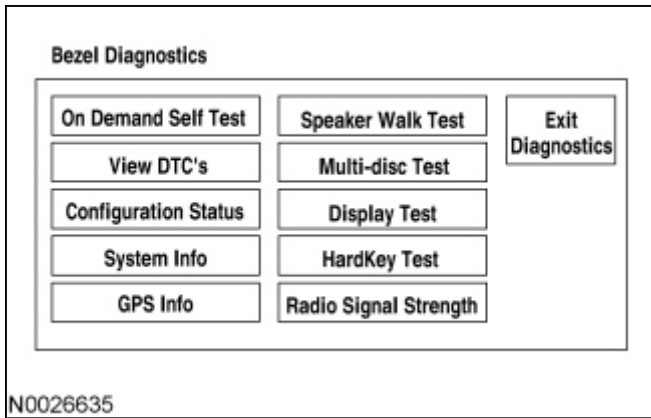

2. The following diagnostic modes are available using the on-screen buttons:
 - "On Demand Self Test" — provides internal self-test diagnostics and displays all the DTCs resulting from the self-test.
 - "View DTC's" — provides a list of all the DTCs currently stored in memory.
 - "Configuration Status" — displays the current unit configuration.
 - "System Info" — provides the navigation module part number and software information.
 - " [GPS](#) Info" — provides satellite information and vehicle current information.
 - "Speaker Walk Test" — performs a speaker walk-around test.
 - "Multi-disc Test" — performs a test of the CD player mechanism.
 - "Display Test" — allows the screen colors to be checked, and allows individual touch sectors of the display screen to be tested.
 - "Hardkey Test" — checks the operation of any [ACM](#) button.
 - "Radio Signal Strength" — performs a test of the AM/FM antenna signal.
3. To exit the self-diagnostic mode, turn the audio system off, turn the key to OFF, or press "Exit Diagnostics".
4. If the concern remains and the fault is not detected, GO to [Symptom Chart - Navigation](#) to continue diagnostics.

Satellite Audio Bezel Diagnostic Test

NOTE: To enter the satellite audio bezel diagnostic test, the audio system must be on and in satellite radio mode.

1. To enter the satellite audio bezel diagnostic test, simultaneously press and hold the AUX button and preset button 2 (except navigation), or the SOUND button and preset button 1 (navigation).
2. Upon entering the self-test, the audio system produces 2 continuously alternating tones of different pitch, one for the right channel, then one for the left.
3. The test continues by displaying any DTCs currently present. If no DTCs are present, NO DTCS will be displayed. If there are DTCs present, the [ACM](#) will auto-scroll through the list of active DTCs.
4. Historical DTCs can be viewed by pressing the AUX button and preset button 2 (except navigation), or the SOUND button and preset button 1 (navigation) simultaneously while in the active DTC mode.
 - If any DTCs are present, pressing the AUX button and preset button 2 (except navigation), or the SOUND button and preset button 1 (navigation) will prompt CLEAR DTCS? on the [ACM](#).
 - To clear historical DTCs, press preset buttons 1, 2, and 3 consecutively within 4 seconds.
 - To exit historical DTCs (with or without clearing DTCs), press the AUX button and preset button 2 (except navigation), or the SOUND button and preset button 1 (navigation) simultaneously.
5. If no historical DTCs are present, pressing the AUX button and preset button 2 (except navigation), or the SOUND button and preset button 1 (navigation) simultaneously while in active DTC mode will display the DLP software version.
6. To exit the satellite audio bezel diagnostic test, press the AUX button and preset button 2 (except

navigation), or the SOUND button and preset button 1 (navigation) simultaneously while the DLP software version is displayed, or turn the audio system off.

- If the concern remains and the fault is not detected, GO to [Symptom Chart - Audio System](#).

DTC Charts

Audio Control Module (ACM) DTC Chart

NOTE: For all U-codes listed in this chart, if no related symptoms are observed, disregard the DTC.

NOTE: For all U-codes listed in this chart, if DTC B1318 is present, diagnose it before diagnosing the U-code DTC.

DTC	Description	Action
B1117	Audio Steering Wheel Button Stuck	DISREGARD the DTC. CLEAR the DTCs.
B1119	Audio Disc DVD Player Thermal Shutdown	The Audio Control Module (ACM) was over temperature. Navigation operation will resume after the ACM cools. This is normal operation. CLEAR the DTCs.
B1136	Audio Steering Wheel Switch #2 Circuit Failure	DISREGARD the DTC. CLEAR the DTCs.
B1140	Map Disk Invalid	REMOVE the map DVD and CLEAN it. INSPECT for scratches, fingerprints, or damage, and REPAIR as necessary. VERIFY a valid map DVD is being used. If no concern is found, INSERT a known good map DVD. REPEAT the self-test. <ul style="list-style-type: none"> If the system operates correctly, the concern was caused by a damaged or invalid map DVD. If DTC B1140 is retrieved again, INSTALL a new ACM. REFER to Audio Control Module (ACM) in this section. TEST the system for normal operation.
B1318	Battery Voltage Low	GO to Pinpoint Test O .
B1342	ECU is Faulted	CLEAR the DTCs. REPEAT the self-test. If DTC B1342 is retrieved again, INSTALL a new ACM . REFER to Audio Control Module (ACM) in this section. TEST the system for normal operation.
B2103	Antenna Not Connected	GO to Pinpoint Test A .
B2204	GPS Antenna Connection Open or Short	GO to Pinpoint Test H .
B2274	Phone Transceiver Active Circuit Failure	DISREGARD the DTC. CLEAR the DTCs.
B2384	Audio Reverse Aid Mute Input Circuit Failure	DISREGARD the DTC. CLEAR the DTCs.
B2404	Audio Steering Wheel Switch Circuit Fault	DISREGARD the DTC. CLEAR the DTCs.
B2405	Audio Disc CD Player Thermal Shutdown Fault	The ACM was over temperature. Audio operation will resume after the ACM cools. This is normal operation. CLEAR the DTCs.
B2406	Audio Disc CD Player Internal Fault	NOTE: DTC B1342 will also be set. CLEAR the DTCs. REPEAT the self-test. If DTC B2406 or B1342 is retrieved again, INSTALL a new ACM . REFER to Audio Control Module (ACM) in this section. TEST the system for normal operation.
B2477	Module Configuration Failure	REFER to Section 418-01 .

B2633	Driver-Front Microphone Circuit Failure	DISREGARD the DTC. CLEAR the DTCs.
B2656	DVD (Digital Versatile Disk) Error	NOTE: DTC B1342 will also be set. CLEAR the DTCs. REPEAT the self-test. If DTC B2656 or B1342 is retrieved again, INSTALL a new ACM . REFER to Audio Control Module (ACM) in this section. TEST the system for normal operation.
B2924	Audio Button Stuck	For the navigation ACM , GO to Pinpoint Test K . For all others, VERIFY no ACM buttons are stuck and that no ACM button was pressed during the self-test. CLEAR the DTCs. REPEAT the self-test. If DTC B2924 is retrieved again, INSTALL a new ACM . REFER to Audio Control Module (ACM) in this section. TEST the system for normal operation.
B2965	Audio System Speaker Circuit Fault	GO to Pinpoint Test B .
C1992	Vehicle Speed Circuit Failure	DISREGARD the DTC. CLEAR the DTCs.
P0812	Reverse Input Circuit	DISREGARD the DTC. CLEAR the DTCs.
U0140	Lost Communication With Body Control Module (GEM)	GO to Pinpoint Test Q .
U0155	Lost Communication With Instrument Panel Cluster (IC) Control Module	If the speed sensitive volume does not operate correctly, GO to Pinpoint Test M . If the navigation is inaccurate, GO to Pinpoint Test L .
U0159	Lost Communication With Parking Assist Control Module (PAM)	DISREGARD the DTC. CLEAR the DTCs.
U0193	Lost Communication With Digital Audio Control Module (SDARS)	GO to Pinpoint Test F .
U0196	Lost Communication With Entertainment Control Module - Rear (AUX)	DISREGARD the DTC. CLEAR the DTCs.
U0197	Lost Communication With Telephone Control Module	DISREGARD the DTC. CLEAR the DTCs.
U0238	Lost Communication With Digital Audio Control Module "D" (DSP)	DISREGARD the DTC. CLEAR the DTCs.
U0249	Lost Communication With Entertainment Control Module - Rear "B" (RCU)	DISREGARD the DTC. CLEAR the DTCs.
U2050	No Application Present	REFER to Section 418-01 .
U2051	One or More Calibration Files Missing/Corrupt	REFER to Section 418-01 .
U2473	Unexpected Vehicle Speed (VSS)	GO to Pinpoint Test L .

Satellite Digital Audio Receiver System (SDARS) Module DTC Chart

NOTE: For all U-codes listed in this chart, if no related symptoms are observed, disregard the DTC.

NOTE: For all U-codes listed in this chart, if DTC B1318 is present, diagnose it before diagnosing the U-code DTC.

DTC	Description	Action
B1031	SDARS Satellite Antenna Open	GO to Pinpoint Test G .
B1032	SDARS Satellite Antenna Short	GO to Pinpoint Test G .
B1318	Battery Voltage Low	GO to Pinpoint Test P .
B1342	ECU is Faulted	CLEAR the DTCs. REPEAT the self-test. If DTC B1342 is retrieved again, INSTALL a new Satellite Digital Audio Receiver System (SDARS) module. REFER to Satellite Digital Audio Receiver System (SDARS) Module in this section. TEST the system for normal operation after the repair.
B2477	Module Configuration Failure	REFER to Section 418-01 .
U0184	Lost Communication With Radio (ACM)	GO to Pinpoint Test F .
U0196	Lost Communication With Entertainment Control Module - Rear (AUX)	DISREGARD the DTC. CLEAR the DTCs.
U0197	Lost Communication With Telephone Control Module	DISREGARD the DTC. CLEAR the DTCs.
U0249	Lost Communication With Entertainment Control Module - Rear "B" (RCU)	DISREGARD the DTC. CLEAR the DTCs.
U2050	No Application Present	REFER to Section 418-01 .

Symptom Chart

Symptom Chart — Audio System

Condition	Possible Sources	Action
<ul style="list-style-type: none"> No communication with the Audio Control Module (ACM) 	<ul style="list-style-type: none"> Fuse Wiring, terminals or connectors ACM 	<ul style="list-style-type: none"> REFER to Section 418-00 .
<ul style="list-style-type: none"> No communication with the Satellite Digital Audio Receiver System (SDARS) module 	<ul style="list-style-type: none"> Fuse Wiring, terminals or connectors SDARS module 	<ul style="list-style-type: none"> REFER to Section 418-00 .
<ul style="list-style-type: none"> The satellite audio is inoperative/does not operate correctly 	<ul style="list-style-type: none"> Subscription status Wiring, terminals or connectors SDARS module ACM 	<ul style="list-style-type: none"> GO to Pinpoint Test F .
<ul style="list-style-type: none"> The Audio Control Module (ACM) backlighting does not operate correctly 	<ul style="list-style-type: none"> Backlighting system concern Wiring, terminals or connectors ACM 	<ul style="list-style-type: none"> REFER to Section 413-00 .
<ul style="list-style-type: none"> Poor reception — AM/FM 	<ul style="list-style-type: none"> Antenna Antenna cable 	<ul style="list-style-type: none"> GO to Pinpoint Test A .

	<ul style="list-style-type: none"> (s) • Charging system • Ignition system • Noise suppression equipment • ACM 	
<ul style="list-style-type: none"> • Poor reception/no sound — satellite audio 	<ul style="list-style-type: none"> • Obstructions to the line of sight • Satellite radio antenna • Satellite radio antenna cable • SDARS module 	<ul style="list-style-type: none"> • GO to Pinpoint Test G .
<ul style="list-style-type: none"> • Continuous seek/scan in AM/FM 	<ul style="list-style-type: none"> • RDS/PTY function setting • Antenna cable (s) • Noise suppression equipment • Antenna • ACM 	<ul style="list-style-type: none"> • GO to Pinpoint Test A .
<ul style="list-style-type: none"> • Poor quality/distorted/no sound from one or more speakers (not all speakers) — except subwoofers 	<ul style="list-style-type: none"> • Wiring, terminals or connectors • Speaker • ACM 	<ul style="list-style-type: none"> • GO to Pinpoint Test B .
<ul style="list-style-type: none"> • Poor quality/distorted/no sound from all speakers 	<ul style="list-style-type: none"> • Wiring, terminals or connectors • ACM 	<ul style="list-style-type: none"> • With the key in any position except START, MEASURE the voltage between the ACM C290d-15, circuit 1000 (RD/BK), harness side and ground. <ul style="list-style-type: none"> ■ If any voltage is present, REPAIR the circuit. TEST the system for normal operation. ■ If no voltage is present, INSTALL a new ACM. REFER to Audio Control Module (ACM) in this section. TEST the system for normal operation.
<ul style="list-style-type: none"> • The subwoofer is inoperative/does not operate correctly — front subwoofers 	<ul style="list-style-type: none"> • Fuse • Wiring, terminals or connectors • Subwoofer amplifier • Front subwoofer • ACM 	<ul style="list-style-type: none"> • GO to Pinpoint Test C .
<ul style="list-style-type: none"> • The subwoofer is inoperative/does not operate correctly — rear subwoofers 	<ul style="list-style-type: none"> • Fuse • Wiring, terminals or connectors • Subwoofer amplifier • Rear subwoofer • ACM 	<ul style="list-style-type: none"> • GO to Pinpoint Test D .
<ul style="list-style-type: none"> • Loud popping sound when 	<ul style="list-style-type: none"> • Fuse 	<ul style="list-style-type: none"> • GO to Pinpoint Test E .

cycling the ignition switch	<ul style="list-style-type: none"> • Wiring, terminals or connectors • Subwoofer amplifier • ACM 	
<ul style="list-style-type: none"> • The speed sensitive volume does not operate correctly. 	<ul style="list-style-type: none"> • Speed sensitive volume setting • Vehicle Speed Sensor (VSS) signal concern • ACM 	<ul style="list-style-type: none"> • GO to Pinpoint Test M.
<ul style="list-style-type: none"> • The audio input jack is inoperative/does not operate correctly 	<ul style="list-style-type: none"> • Wiring, terminals or connectors • Audio input jack • ACM 	<ul style="list-style-type: none"> • GO to Pinpoint Test N.

Symptom Chart — Navigation

Condition	Possible Sources	Action
<ul style="list-style-type: none"> • No Global Positioning System (GPS) antenna signal 	<ul style="list-style-type: none"> • GPS antenna • Audio Control Module (ACM) 	<ul style="list-style-type: none"> • GO to Pinpoint Test H.
<ul style="list-style-type: none"> • Navigation screen only displays Dearborn, Michigan 	<ul style="list-style-type: none"> • GPS antenna 	<ul style="list-style-type: none"> • GO to Pinpoint Test L.
<ul style="list-style-type: none"> • The position cursor is inaccurate 	<ul style="list-style-type: none"> • Navigation rolling wheel count data concern • ACM 	<ul style="list-style-type: none"> • GO to Pinpoint Test L.
<ul style="list-style-type: none"> • The audible switch feedback is inoperative 	<ul style="list-style-type: none"> • Audible switch feedback setting • ACM 	<ul style="list-style-type: none"> • GO to Pinpoint Test I.
<ul style="list-style-type: none"> • The voice guidance is inoperative/does not operate correctly 	<ul style="list-style-type: none"> • Incorrect system setting • ACM 	<ul style="list-style-type: none"> • GO to Pinpoint Test J.
<ul style="list-style-type: none"> • The display screen is inoperative 	<ul style="list-style-type: none"> • ACM 	<ul style="list-style-type: none"> • GO to Pinpoint Test R.
<ul style="list-style-type: none"> • Unable to read map disc 	<ul style="list-style-type: none"> • Map DVD • ACM 	<ul style="list-style-type: none"> • REMOVE the map DVD and CLEAN it. INSPECT for scratches, fingerprints, or damage, and REPAIR as necessary. VERIFY a valid map DVD is being used. If no concern is found, INSERT a known good map DVD. TEST the system. <ul style="list-style-type: none"> ■ If the system operates correctly, the concern was caused by a damaged or inoperable map DVD. ■ If the system does not operate correctly, INSTALL a new ACM. REFER to Audio Control Module (ACM) in this section. TEST the system for normal operation.
<ul style="list-style-type: none"> • The screen does not open/close 	<ul style="list-style-type: none"> • Trim panel interference • ACM 	<ul style="list-style-type: none"> • INSPECT the instrument panel center trim panel for interference with the navigation screen and REPAIR as necessary. If no interference is found,

INSTALL a new [ACM](#). REFER to [Audio Control Module \(ACM\)](#) in this section.
TEST the system for normal operation.

Pinpoint Tests

Pinpoint Test A: Poor Reception — AM/FM

Normal Operation

The noise suppression equipment reduces interference transmitted through the speakers by the engine ignition and electrical systems.

- DTC B2103 (Antenna Not Connected) — sets when the signal strength is less than a pre-determined value during the "antenna connected test" portion of the Audio Control Module (ACM) self-test. This DTC may not set, even if there is an open in the antenna coaxial cable; however, if it does set, the antenna circuit can be isolated for diagnosis.

This pinpoint test is intended to diagnose the following:

- Antenna
- Antenna cable(s)
- Charging system
- Ignition system
- Noise suppression equipment
- [ACM](#)

PINPOINT TEST A: POOR RECEPTION — AM/FM

Test Step	Result / Action to Take
A1 REVIEW THE DTCs	
<ul style="list-style-type: none"> • Review the DTCs from the ACM self-test. • Is DTC B2103 present? 	<p>Yes GO to A7.</p> <p>No GO to A2.</p>
A2 CHECK THE AUDIO SYSTEM RECEPTION	
<ul style="list-style-type: none"> • Check the ACM signal reception with the engine running, and with the engine off. • Does the poor reception only occur with the engine running? 	<p>Yes GO to A3.</p> <p>No GO to A7.</p>
A3 CHECK THE SUPPRESSION EQUIPMENT/MOUNTING AND CONNECTING CIRCUITS	
<ul style="list-style-type: none"> • Ignition OFF. • Check all necessary suppression equipment and the radio frequency interference suppression bond. • NOTE: The capacitor mounting points are used to complete the electrical circuit and must be mounted securely to clean surfaces. • Check the mounting and connecting circuits of the radio interference capacitor for integrity, cleanliness, and metal-to-metal contact. 	<p>Yes GO to A4.</p> <p>No CLEAN, SECURE, or INSTALL new suppression equipment as necessary. TEST the system for normal operation.</p>

<ul style="list-style-type: none"> • Are the connections clean, secure, and in metal-to-metal contact? 	
A4 CHECK THE RADIO INTERFERENCE CAPACITOR	
<ul style="list-style-type: none"> • Check the operation of the radio interference capacitor by installing a known good component. • Start the vehicle. • Operate the audio system in radio tuner (AM/FM) mode. • Is the reception OK? 	<p>Yes INSTALL a new radio interference capacitor. TEST the system for normal operation.</p> <p>No INSTALL the original radio interference capacitor. GO to A5.</p>
A5 CHECK THE GENERATOR	
<ul style="list-style-type: none"> • Ignition OFF. • Check the generator by disconnecting the voltage regulator. • Start the vehicle. • Operate the audio system in radio tuner (AM/FM) mode. • Is the reception OK? 	<p>Yes INSTALL a new generator. REFER to Section 414-00. TEST the system for normal operation.</p> <p>No TURN the key to OFF. CONNECT the voltage regulator. GO to A6.</p>
A6 CHECK THE IGNITION CIRCUITS	
<ul style="list-style-type: none"> • Check the ignition circuits for correct routing, ground, and integrity of connections. • Check the spark plugs and ignition coils. • Are the ignition components OK? 	<p>Yes GO to A10.</p> <p>No REPAIR the ignition system as necessary. TEST the system for normal operation.</p>
A7 CHECK THE ANTENNA GROUND	
<ul style="list-style-type: none"> • Ignition OFF. • Measure the resistance between the antenna base and the battery ground cable. • Is the resistance less than 5 ohms? 	<p>Yes GO to A9.</p> <p>No GO to A8.</p>
A8 CHECK THE ANTENNA CABLE CONNECTIONS	
<ul style="list-style-type: none"> • Check the antenna connections, including the extension cable. • Check to make sure the antenna is securely mounted to the vehicle body at ground points. • Are the connections clean, secure, and in metal-to-metal contact? 	<p>Yes GO to A9.</p> <p>No CLEAN and SECURE the antenna connections as necessary. CLEAR the DTCs. REPEAT the self-test.</p>
A9 SUBSTITUTE THE ANTENNA	
<ul style="list-style-type: none"> • Substitute a known good antenna. • Ignition ON. • Operate the audio system in radio tuner (AM/FM) mode. • Is the reception OK? 	<p>Yes INSTALL a new antenna. CLEAR the DTCs. REPEAT the self-test.</p> <p>No TURN the key to OFF. INSTALL the original antenna. GO to A10.</p>
A10 SUBSTITUTE THE ANTENNA CABLE	
<ul style="list-style-type: none"> • Substitute a known good antenna cable. • Ignition ON. • Operate the audio system in radio tuner (AM/FM) mode. • Is the reception OK? 	<p>Yes INSTALL a new antenna cable. REFER to Antenna Lead-In Cable in this section. CLEAR the DTCs. REPEAT the self-test.</p> <p>No TURN the key to OFF. INSTALL the original antenna cable. GO to A11.</p>
A11 CHECK FOR CORRECT ACM OPERATION	

- Disconnect all the [ACM](#) connectors.
- Check for:
 - corrosion
 - damaged pins
 - pushed-out pins
- Connect all the [ACM](#) connectors and make sure they seat correctly.
- Operate the system and determine if the concern is still present.
- **Is the concern still present?**

Yes

INSTALL a new [ACM](#). REFER to [Audio Control Module \(ACM\)](#) in this section. TEST the system for normal operation.

No

The system is operating correctly at this time. The concern may have been caused by a loose or corroded connector. CLEAR the DTCs. REPEAT the self-test.

Pinpoint Test B: Poor Quality/Distorted/No Sound from One or More Speakers (Not All Speakers) — Except Subwoofers

Refer to Wiring Diagrams Cell [130](#), Audio System/Navigation for schematic and connector information.

Normal Operation

The Audio Control Module (ACM) directs the audio signals to the speakers through separate positive and negative circuits for each of the audio channels. The [ACM](#) provides internal circuit protection for shorts to ground, shorts to voltage, or shorts between any output circuits.

- DTC B2965 (Audio System Speaker Circuit Fault) — sets when an open, a short to ground, or a short to voltage is detected on the front door or rear door speaker circuits. The [ACM](#) checks these circuits during the self-test, and checks them every 500 milliseconds during normal operation.

This pinpoint test is intended to diagnose the following:

- Wiring, terminals or connectors
- Speaker
- [ACM](#)

PINPOINT TEST B: POOR QUALITY/DISTORTED/NO SOUND FROM ONE OR MORE SPEAKERS (NOT ALL SPEAKERS) — EXCEPT SUBWOOFERS

NOTICE: Use the correct probe adapter(s) when making measurements. Failure to use the correct probe adapter(s) may damage the connector.

Test Step	Result / Action to Take
B1 CHECK FOR OTHER CONCERNS	
<ul style="list-style-type: none"> • Ignition OFF. • Remove the trim panel for the suspect speaker. Refer to Section 501-05. • Remove the speaker and check for: <ul style="list-style-type: none"> ▪ connector integrity ▪ debris in the speaker cone • Install the speaker, but leave the trim panel off. • Ignition ON. • Operate the audio system in radio tuner (AM/FM) mode. • Observe the operation of the suspect speaker. • Is the speaker sound OK? 	<p>Yes INSPECT the trim panel and REPAIR as necessary. TEST the system for normal operation.</p> <p>No GO to B2.</p>
B2 CHECK THE SPEAKER CIRCUITS FOR VOLTAGE	
<ul style="list-style-type: none"> • Ignition OFF. • Disconnect: Suspect Speaker. • Ignition ON. • Operate the audio system in radio tuner (AM/FM) mode. • Measure the AC voltage between the suspect speaker pin 1 and pin 2, harness side as follows: 	<p>Yes INSTALL a new speaker for the suspect speaker. REFER to Door Speaker or Quarter Panel Speaker in this section. CLEAR the DTCs. REPEAT the speaker walk-around test.</p>

Suspect Speaker	Connector-Pin/ Circuit	Connector-Pin/ Circuit
LH front	C523-1	C523-2
	1723 (OG/LG)	1722 (LB/WH)
RH front	C612-1	C612-2
	1778 (WH/LG)	1777 (DG/OG)
LH rear	C484-1	C484-2
	1726 (GY/LB)	1725 (TN/YE)
RH rear	C485-1	C485-2
	1781 (OG/RD)	1780 (BN/PK)

No
GO to [B3](#).

- Is an alternating AC voltage present?

B3 CHECK THE SPEAKER CIRCUITS FOR A SHORT TO VOLTAGE

- Ignition OFF.
- Disconnect: [ACM](#) C290d.
- Ignition ON.
- Measure the voltage between the suspect speaker, harness side and ground as follows:

Suspect Speaker	Connector-Pin	Circuit
LH front	C523-1	1723 (OG/LG)
	C523-2	1722 (LB/WH)
RH front	C612-1	1778 (WH/LG)
	C612-2	1777 (DG/OG)
LH rear	C484-1	1726 (GY/LB)
	C484-2	1725 (TN/YE)
RH rear	C485-1	1781 (OG/RD)
	C485-2	1780 (BN/PK)

- Is any voltage present?

Yes
REPAIR the circuit in question.
CLEAR the DTCs. REPEAT the speaker walk-around test.

No
GO to [B4](#).

B4 CHECK THE SPEAKER CIRCUITS FOR AN OPEN OR SHORT TO GROUND

- Ignition OFF.
- Measure the resistance between the suspect speaker, harness side and the [ACM](#), harness side; and between the suspect speaker, harness side and ground as follows:

Suspect Speaker	Speaker Connector- Pin	ACM Connector- Pin	Circuit
LH front	C523-1	C290d-8	1723 (OG/LG)
LH front	C523-2	C290d-21	1722 (LB/WH)
RH front	C612-1	C290d-11	1778 (WH/LG)

Yes
GO to [B5](#).

No
REPAIR the circuit in question.
CLEAR the DTCs. REPEAT the speaker walk-around test.

RH front	C612-2	C290d-12	1777 (DG/OG)
LH rear	C484-1	C290d-9	1726 (GY/LB)
LH rear	C484-2	C290d-22	1725 (TN/YE)
RH rear	C485-1	C290d-10	1781 (OG/RD)
RH rear	C485-2	C290d-23	1780 (BN/PK)

- Is the resistance less than 5 ohms between the suspect speaker and the **ACM**, and greater than 10,000 ohms between the suspect speaker and ground?

B5 CHECK FOR CORRECT **ACM** OPERATION

- Disconnect all the **ACM** connectors.
- Check for:
 - corrosion
 - damaged pins
 - pushed-out pins
- Connect all the **ACM** connectors and make sure they seat correctly.
- Operate the system and determine if the concern is still present.
- **Is the concern still present?**

Yes

INSTALL a new **ACM**. REFER to [Audio Control Module \(ACM\)](#) in this section. TEST the system for normal operation.

No

The system is operating correctly at this time. The concern may have been caused by a loose or corroded connector. CLEAR the DTCs. REPEAT the self-test.

Pinpoint Test C: The Subwoofer is Inoperative/Does Not Operate Correctly — Front Subwoofer

Refer to Wiring Diagrams Cell [130](#), Audio System/Navigation for schematic and connector information.

Normal Operation

The front subwoofers are powered by a separate subwoofer amplifier for each subwoofer speaker. The enable/clip circuit 173 (DG/VT) carries out 2 functions: to turn on the subwoofer amplifiers, and monitor an overload condition to the subwoofer amplifier. In the event of an overload, the Audio Control Module (ACM) clips the audio output signal to the subwoofer amplifiers (heard as distortion). The front subwoofer amplifiers receive voltage through circuit 829 (WH/VT), and ground through circuit 1204 (BK/OG).

This pinpoint test is intended to diagnose the following:

- Fuse
- Wiring, terminals or connectors
- Subwoofer amplifier
- Subwoofer
- **ACM**

PINPOINT TEST C: THE SUBWOOFER IS INOPERATIVE/DOES NOT OPERATE CORRECTLY — FRONT SUBWOOFER

NOTICE: Use the correct probe adapter(s) when making measurements. Failure to use the correct probe adapter(s) may damage the connector.

Test Step	Result / Action to Take
C1 CHECK CIRCUIT 829 (WH/VT) FOR VOLTAGE	

- Ignition OFF.
- Disconnect: Left Front Subwoofer Amplifier C2993a and Right Front Subwoofer Amplifier C2994a.
- Measure the voltage between the left front subwoofer amplifier C2993a-5, circuit 829 (WH/VT), harness side and ground; and between the right front subwoofer amplifier C2994a-5, circuit 829 (WH/VT), harness side and ground.

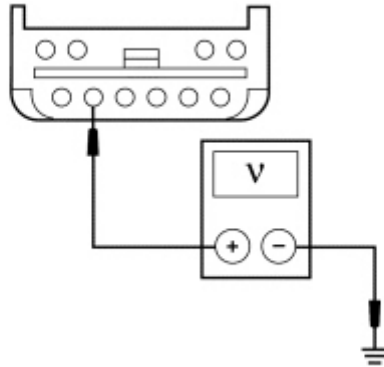

A0021366

- Are the voltages greater than 10 volts?

Yes
GO to [C2](#).

No
VERIFY the Bussed Electrical Center (BEC) fuse 16 (30A) is OK. If OK, REPAIR the circuit in question. TEST the system for normal operation. If not OK, REFER to the Wiring Diagrams Manual to identify the possible causes of the circuit short.

C2 CHECK CIRCUIT 1204 (BK/OG) FOR AN OPEN

- Measure the resistance between the left front subwoofer amplifier C2993a-2, circuit 1204 (BK/OG), harness side and ground; and between the right front subwoofer amplifier C2994a-2, circuit 1204 (BK/OG), harness side and ground.

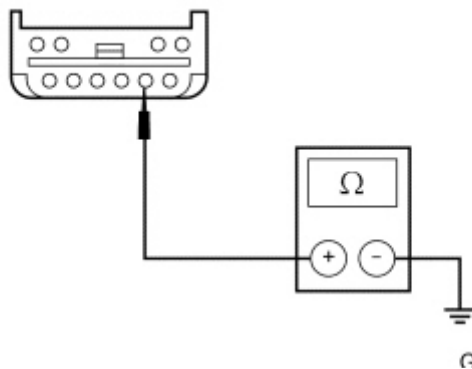

GK5794-A

- Are the resistances less than 5 ohms?

Yes
GO to [C3](#).

No
REPAIR the circuit in question. TEST the system for normal operation.

C3 CHECK CIRCUIT 173 (DG/VT) FOR VOLTAGE

- Ignition ON.
- Operate the audio system in radio tuner (AM/FM) mode.
- Measure the voltage between the left front subwoofer amplifier C2993a-1, circuit 173 (DG/VT), harness side and ground; and between the right front subwoofer amplifier C2994a-1, circuit 173 (DG/VT), harness side and ground.

Yes
GO to [C6](#).

No
If the voltage is incorrect at one amplifier only, REPAIR the circuit in question. TEST the system for normal operation.

If the voltage is incorrect at both amplifiers, GO to [C4](#).

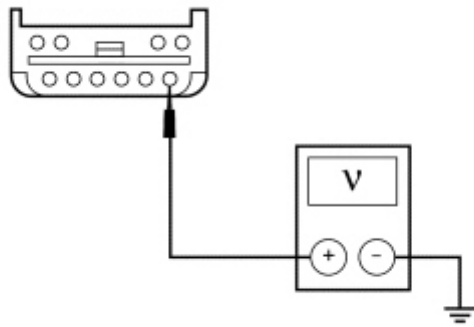

GK4985-A

- Is the voltage between 3.8 and 6.7 volts at both amplifiers?

C4 CHECK CIRCUIT 173 (DG/VT) FOR A SHORT TO VOLTAGE

- Ignition OFF.
- Disconnect: [ACM C290b](#).
- Ignition ON.
- Measure the voltage between the left front subwoofer amplifier C2993a-1, circuit 173 (DG/VT), harness side and ground.

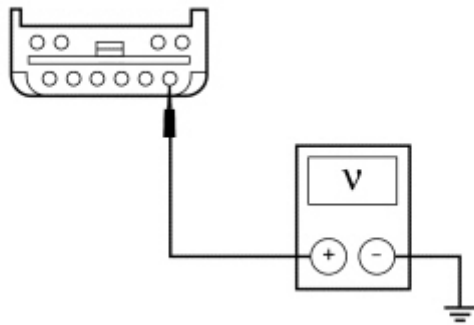

GK4985-A

- Is any voltage present?

Yes
REPAIR the circuit.
TEST the system for normal operation.

No
GO to [C5](#).

C5 CHECK CIRCUIT 173 (DG/VT) FOR AN OPEN OR SHORT TO GROUND

- Ignition OFF.
- Measure the resistance between the left front subwoofer amplifier C2993a-1, circuit 173 (DG/VT), harness side and the [ACM C290b-4](#), circuit 173 (DG/VT), harness side; and between the left front subwoofer amplifier C2993a-1, circuit 173 (DG/VT), harness side and ground.
- Is the resistance less than 5 ohms between the left front subwoofer amplifier and the [ACM](#), and greater than 10,000 ohms between the left front subwoofer amplifier and ground?

Yes
GO to [C13](#).

No
REPAIR the circuit.
TEST the system for normal operation.

C6 CHECK THE AUDIO SIGNALS TO THE FRONT SUBWOOFER AMPLIFIER

- Operate the audio system in radio tuner (AM/FM) mode.
- Measure the AC voltage between the left front subwoofer amplifier C2993a-7, circuit 167 (BN/OG), harness side and the left front subwoofer amplifier C2993a-8, circuit 168 (RD/BK), harness side; and between the right front subwoofer amplifier C2994a-7, circuit 167 (BN/OG), harness side and the right front subwoofer amplifier C2994a-8, circuit 168 (RD/BK), harness side.

Yes
GO to [C10](#).

No
If the voltage is incorrect at one amplifier only, GO to [C7](#).

If the voltage is incorrect at both amplifiers, GO to [C8](#).

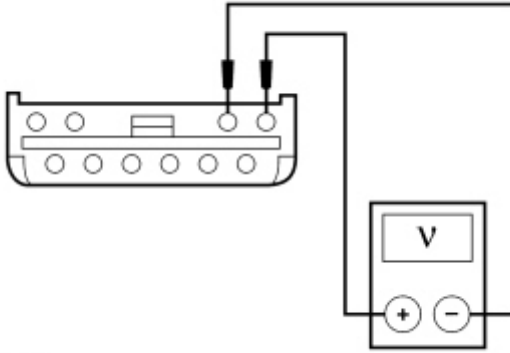

A0057176

- Is a fluctuating AC voltage present at both amplifiers?

C7 CHECK CIRCUIT 167 (BN/OG) FOR AN OPEN

NOTE: Carry out this step only for the inoperative subwoofer.

- Ignition OFF.
- Disconnect: [ACM C290b](#).
- Measure the resistance between the left front subwoofer amplifier C2993a-7, circuit 167 (BN/OG), harness side and the [ACM C290b-1](#), circuit 167 (BN/OG), harness side; or between the right front subwoofer amplifier C2994a-7, circuit 167 (BN/OG), harness side and the [ACM C290b-1](#), circuit 167 (BN/OG), harness side.

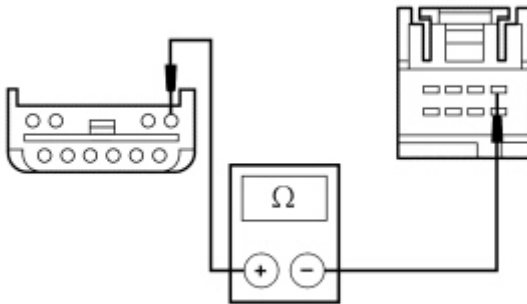

N0056195

- Is the resistance less than 5 ohms?

Yes
REPAIR circuit 168 (RD/BK). TEST the system for normal operation.

No
REPAIR circuit 167 (BN/OG). TEST the system for normal operation.

C8 CHECK CIRCUITS 167 (BN/OG) AND 168 (RD/BK) FOR A SHORT TO VOLTAGE

- Ignition OFF.
- Disconnect: [ACM C290b](#).
- Ignition ON.
- Measure the voltage between the left front subwoofer amplifier C2993a-7, circuit 167 (BN/OG), harness side and ground; and between the left front subwoofer amplifier C2993a-8, circuit 168 (RD/BK), harness side and ground.

Yes
REPAIR the circuit in question. TEST the system for normal operation.

No
GO to [C9](#).

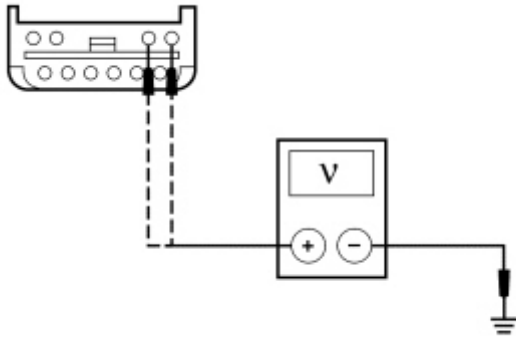

N0035293

- Is any voltage present?

C9 CHECK CIRCUITS 167 (BN/OG) AND 168 (RD/BK) FOR AN OPEN OR SHORT TO GROUND

- Ignition OFF.
- Measure the resistance between the left front subwoofer amplifier, harness side and the **ACM**, harness side; and between the left front subwoofer amplifier, harness side and ground as follows:

Subwoofer Amplifier Connector-Pin	ACM Connector-Pin	Circuit
C2993a-7	C290b-1	167 (BN/OG)
C2993a-8	C290b-2	168 (RD/BK)

- Is the resistance less than 5 ohms between the left front subwoofer amplifier and the **ACM**, and greater than 10,000 ohms between the left front subwoofer amplifier and ground?

Yes
GO to [C13](#).

No
REPAIR the circuit in question. TEST the system for normal operation.

C10 CHECK THE AUDIO CIRCUITS TO THE SUSPECT FRONT SUBWOOFER

- Ignition OFF.
- Connect: Left Front Subwoofer Amplifier C2993a and Right Front Subwoofer Amplifier C2994a.
- Disconnect: Left Front Subwoofer C536 or Right Front Subwoofer C628.
- Ignition ON.
- Operate the audio system in radio tuner (AM/FM) mode.
- Measure the AC voltage between the suspect front subwoofer circuits, harness side as follows:

Suspect Subwoofer	Subwoofer Connector-Pin/ Circuit	Subwoofer Connector-Pin/ Circuit
Left front	C536-1	C536-2
	804 (OG/LG)	813 (LB/WH)
Left front	C536-3	C536-4
	820 (DB/YE)	819 (LG/WH)
Right front	C628-1	C628-2
	805 (WH/LG)	811 (DG/OG)
Right front	C628-3	C628-4
	816 (LG/VT)	815 (LG/OG)

- Is a fluctuating AC voltage present?

Yes
INSTALL a new subwoofer for the suspect subwoofer. REFER to [Subwoofer Speaker](#) in this section. TEST the system for normal operation.

No
GO to [C11](#).

C11 CHECK THE AUDIO CIRCUITS TO THE SUSPECT SUBWOOFER FOR A SHORT TO VOLTAGE

- Ignition OFF.
- Disconnect: Left Front Subwoofer Amplifier C2993b and Right Front Subwoofer Amplifier C2994b.
- Ignition ON.
- Measure the voltage between the suspect front subwoofer, harness side and ground as follows:

Suspect Subwoofer	Subwoofer Connector-Pin	Circuit
Left front	C536-1	804 (OG/LG)
	C536-2	813 (LB/WH)
	C536-3	820 (DB/YE)
	C536-4	819 (LG/WH)
Right front	C628-1	805 (WH/LG)
	C628-2	811 (DG/OG)
	C628-3	816 (LG/VT)
	C628-4	815 (LG/OG)

- Is any voltage present?

Yes
REPAIR the circuit in question. TEST the system for normal operation.

No
GO to [C12](#).

C12 CHECK THE AUDIO CIRCUITS TO THE SUSPECT SUBWOOFER FOR AN OPEN OR SHORT TO GROUND

- Ignition OFF.
- Measure the resistance between the suspect front subwoofer, harness side and the front amplifier, harness side; and between the suspect front subwoofer, harness side and ground as follows:

Suspect Subwoofer	Subwoofer Connector- Pin	Subwoofer Amplifier Connector- Pin	Circuit
Left front	C536-1	C2993b-1	804 (OG/LG)
	C536-2	C2993b-2	813 (LB/WH)
	C536-3	C2993b-3	820 (DB/YE)
	C536-4	C2993b-4	819 (LG/WH)
Right front	C628-1	C2994b-1	805 (WH/LG)
	C628-2	C2994b-2	811 (DG/OG)
	C628-3	C2994b-3	816 (LG/VT)
	C628-4	C2994b-4	815 (LG/OG)

- Is the resistance less than 5 ohms between the suspect front subwoofer and the front subwoofer amplifier, and greater than 10,000 ohms between the suspect front subwoofer and ground?

Yes
INSTALL a new front subwoofer amplifier for the suspect amplifier. REFER to [Subwoofer Amplifier — Door](#) in this section. TEST the system for normal operation.

No
REPAIR the circuit in question. TEST the system for normal operation.

C13 CHECK FOR CORRECT [ACM](#) OPERATION

- Disconnect all the [ACM](#) connectors.
- Check for:
 - corrosion
 - damaged pins
 - pushed-out pins

Yes
INSTALL a new [ACM](#). REFER to [Audio Control Module \(ACM\)](#) in this section. TEST the

- Connect all the [ACM](#) connectors and make sure they seat correctly.
- Operate the system and determine if the concern is still present.
- **Is the concern still present?**

system for normal operation.

No

The system is operating correctly at this time. The concern may have been caused by a loose or corroded connector.

Pinpoint Test D: The Subwoofer is Inoperative/Does Not Operate Correctly — Rear Subwoofer

Refer to Wiring Diagrams Cell [130](#), Audio System/Navigation for schematic and connector information.

Normal Operation

The rear subwoofers are powered by a separate subwoofer amplifier for each subwoofer speaker. The enable/clip circuit 174 (GY/BK) carries out 2 functions: to turn on the subwoofer amplifiers, and monitor an overload condition to the subwoofer amplifiers. In the event of an overload, the Audio Control Module (ACM) clips the audio output signal to the subwoofer amplifiers (heard as distortion). The rear subwoofer amplifiers receive voltage through circuit 828 (VT/LB) (right subwoofers) or circuit 830 (PK/YE) (left subwoofers), and ground through circuit 1204 (BK/OG).

This pinpoint test is intended to diagnose the following:

- Fuse
- Wiring, terminals or connectors
- Subwoofer amplifier
- Subwoofer
- [ACM](#)

PINPOINT TEST D: THE SUBWOOFER IS INOPERATIVE/DOES NOT OPERATE CORRECTLY — REAR SUBWOOFER

NOTICE: Use the correct probe adapter(s) when making measurements. Failure to use the correct probe adapter(s) may damage the connector.

Test Step	Result / Action to Take															
<p>D1 CHECK CIRCUIT 828 (VT/LB) OR 830 (PK/YE) FOR VOLTAGE</p> <ul style="list-style-type: none"> • Ignition OFF. • Disconnect: Suspect Subwoofer Amplifier(s). • Measure the voltage between the suspect subwoofer amplifier, harness side and ground as follows: <table border="1"> <thead> <tr> <th>Suspect Subwoofer Amplifier</th> <th>Subwoofer Amplifier Connector-Pin</th> <th>Circuit</th> </tr> </thead> <tbody> <tr> <td>Left outboard</td> <td>C4157a-5</td> <td>830 (PK/YE)</td> </tr> <tr> <td>Left inboard</td> <td>C4158a-5</td> <td>828 (VT/LB)</td> </tr> <tr> <td>Right inboard</td> <td>C4159a-5</td> <td>830 (PK/YE)</td> </tr> <tr> <td>Right outboard</td> <td>C4160a-5</td> <td>828 (VT/LB)</td> </tr> </tbody> </table> <ul style="list-style-type: none"> • Is the voltage greater than 10 volts? 	Suspect Subwoofer Amplifier	Subwoofer Amplifier Connector-Pin	Circuit	Left outboard	C4157a-5	830 (PK/YE)	Left inboard	C4158a-5	828 (VT/LB)	Right inboard	C4159a-5	830 (PK/YE)	Right outboard	C4160a-5	828 (VT/LB)	<p>Yes GO to D2.</p> <p>No VERIFY the Bussed Electrical Center (BEC) fuse 6 (30A) or fuse 9 (30A) is OK. If OK, REPAIR the circuit in question. TEST the system for normal operation. If not OK, REFER to the Wiring Diagrams Manual to identify the possible causes of the circuit short.</p>
Suspect Subwoofer Amplifier	Subwoofer Amplifier Connector-Pin	Circuit														
Left outboard	C4157a-5	830 (PK/YE)														
Left inboard	C4158a-5	828 (VT/LB)														
Right inboard	C4159a-5	830 (PK/YE)														
Right outboard	C4160a-5	828 (VT/LB)														

D2 CHECK CIRCUIT 1204 (BK/OG) FOR AN OPEN

- Measure the resistance between the suspect subwoofer amplifier, harness side and ground as follows:

Suspect Subwoofer Amplifier	Subwoofer Amplifier Connector-Pin	Circuit
Left outboard	C4157a-2	1204 (BK/OG)
Left inboard	C4158a-2	1204 (BK/OG)
Right inboard	C4159a-2	1204 (BK/OG)
Right outboard	C4160a-2	1204 (BK/OG)

- Is the resistance less than 5 ohms?

Yes
GO to [D3](#).

No
REPAIR the circuit in question. TEST the system for normal operation.

D3 CHECK CIRCUIT 174 (GY/BK) FOR VOLTAGE

- Ignition ON.
- Operate the audio system in radio tuner (AM/FM) mode.
- Measure the voltage between the suspect subwoofer speaker, harness side and ground as follows:

Suspect Subwoofer Amplifier	Subwoofer Amplifier Connector-Pin	Circuit
Left outboard	C4157a-1	174 (GY/BK)
Left inboard	C4158a-1	174 (GY/BK)
Right inboard	C4159a-1	174 (GY/BK)
Right outboard	C4160a-1	174 (GY/BK)

- Is the voltage between 3.8 and 6.7 volts?

Yes
GO to [D6](#).

No
GO to [D4](#).

D4 CHECK CIRCUIT 174 (GY/BK) FOR A SHORT TO VOLTAGE

- Ignition OFF.
- Disconnect: [ACM](#) C290b.
- Ignition ON.
- Measure the voltage between the [ACM](#) C290b-8, circuit 174 (GY/BK), harness side and ground.

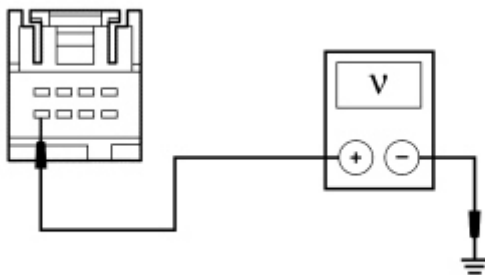

N0056196

- Is any voltage present?

Yes
REPAIR the circuit. TEST the system for normal operation.

No
GO to [D5](#).

D5 CHECK CIRCUIT 174 (GY/BK) FOR AN OPEN OR SHORT TO

GROUND

- Ignition OFF.
- Measure the resistance between the suspect subwoofer amplifier pin 1, circuit 174 (GY/BK), harness side and the **ACM** C290b-8, circuit 174 (GY/BK), harness side; and between the suspect subwoofer speaker pin 1, circuit 174 (GY/BK), harness side and ground.

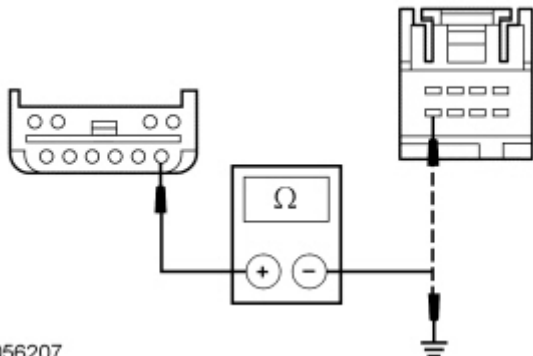

N0056207

- Is the resistance less than 5 ohms between the suspect subwoofer amplifier and the **ACM**, and greater than 10,000 ohms between the suspect subwoofer amplifier and ground?

Yes
GO to [D12](#).

No
REPAIR the circuit. TEST the system for normal operation.

D6 CHECK THE AUDIO SIGNALS TO THE SUSPECT SUBWOOFER AMPLIFIER

- Operate the audio system in radio tuner (AM/FM) mode.
- Measure the AC voltage at the suspect subwoofer amplifier, harness side as follows:

Suspect Subwoofer Amplifier	Subwoofer Amplifier Connector-Pin/ Circuit	Subwoofer Amplifier Connector-Pin/ Circuit
Left outboard	C4157a-7	C4157a-8
	179 (OG/RD)	176 (PK/LG)
Left inboard	C4158a-7	C4158a-8
	179 (OG/RD)	176 (PK/LG)
Right inboard	C4159a-7	C4159a-8
	179 (OG/RD)	176 (PK/LG)
Right outboard	C4160a-7	C4160a-8
	179 (OG/RD)	176 (PK/LG)

- Is a fluctuating AC voltage present?

Yes
GO to [D9](#).

No
GO to [D7](#).

D7 CHECK CIRCUITS 176 (PK/LG) AND 179 (OG/RD) FOR A SHORT TO VOLTAGE

- Ignition OFF.
- Disconnect: **ACM** C290b.
- Ignition ON.
- Measure the voltage between the **ACM** C290b-5, circuit 176 (PK/LG), harness side and ground; and between the **ACM** C290b-6, circuit 179 (OG/RD), harness side and ground.

Yes
REPAIR the circuit in question. TEST the system for normal operation.

No
GO to [D8](#).

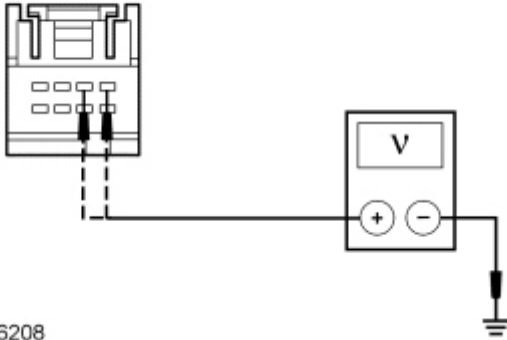

N0056208

- Is any voltage present?

D8 CHECK CIRCUITS 176 (PK/LG) AND 179 (OG/RD) FOR AN OPEN OR SHORT TO GROUND

- Ignition OFF.
- Measure the resistance between the suspect subwoofer amplifier, harness side and the **ACM**, harness side; and between the suspect subwoofer amplifier, harness side and ground as follows:

Suspect Subwoofer Amplifier	Subwoofer Amplifier Connector- Pin	ACM Connector- Pin	Circuit
Left outboard	C4157a-7	C290b-6	179 (OG/RD)
	C4157a-8	C290b-5	176 (PK/LG)
Left inboard	C4158a-7	C290b-6	179 (OG/RD)
	C4158a-8	C290b-5	176 (PK/LG)
Right outboard	C4159a-7	C290b-6	179 (OG/RD)
	C4159a-8	C290b-5	176 (PK/LG)
Right inboard	C4160a-7	C290b-6	179 (OG/RD)
	C4160a-8	C290b-5	176 (PK/LG)

- Is the resistance less than 5 ohms between the suspect subwoofer amplifier and the **ACM**, and greater than 10,000 ohms between the suspect subwoofer amplifier and ground?

Yes
GO to [D12](#).

No
REPAIR the circuit in question. TEST the system for normal operation.

D9 CHECK THE AUDIO CIRCUITS TO THE SUSPECT REAR SUBWOOFER

- Ignition OFF.
- Connect: Suspect Subwoofer Amplifier.
- Disconnect: Suspect Rear Subwoofer.
- Ignition ON.
- Operate the audio system in radio tuner (AM/FM) mode.
- Measure the AC voltage between the suspect rear subwoofer circuits, harness side as follows:

Suspect Subwoofer	Subwoofer Connector-Pin/ Circuit	Subwoofer Connector-Pin/ Circuit
Left outboard	C4161-1	C4161-2

Yes
INSTALL a new subwoofer for the suspect subwoofer. REFER to [Subwoofer Speaker](#) in this section. TEST the system for normal operation.

No
GO to [D10](#).

	800 (GY/LB)	801 (TN/YE)
Left inboard	C4161-3	C4161-4
	806 (PK/LB)	807 (PK/LG)
Right outboard	C4162-1	C4162-2
	802 (OG/RD)	803 (BN/PK)
Right inboard	C4162-3	C4162-4
	825 (TN/LG)	827 (TN/WH)

- Is a fluctuating AC voltage present?

D10 CHECK THE AUDIO CIRCUITS TO THE SUSPECT SUBWOOFER FOR A SHORT TO VOLTAGE

- Ignition OFF.
- Disconnect: Suspect Subwoofer Amplifier C4157b, C4158b, C4159b, or C4160b.
- Ignition ON.
- Measure the voltage between the suspect rear subwoofer, harness side and ground as follows:

Suspect Subwoofer	Subwoofer Connector-Pin	Circuit
Left outboard	C4161-1	800 (GY/LB)
	C4161-2	801 (TN/YE)
Left inboard	C4161-3	806 (PK/LB)
	C4161-4	807 (PK/LG)
Right inboard	C4162-1	802 (OG/RD)
	C4162-2	803 (BN/PK)
Right outboard	C4162-3	825 (TN/LG)
	C4162-4	827 (TN/WH)

- Is any voltage present?

D11 CHECK THE AUDIO CIRCUITS TO THE SUSPECT SUBWOOFER FOR AN OPEN OR SHORT TO GROUND

- Ignition OFF.
- Measure the resistance between the suspect rear subwoofer, harness side and the rear amplifier, harness side; and between the suspect rear subwoofer, harness side and ground as follows:

Suspect Subwoofer	Subwoofer Connector-Pin	Rear Amplifier Connector-Pin	Circuit
Left outboard	C4161-1	C4157b-4	800 (GY/LB)
	C4161-2	C4157b-3	801 (TN/YE)
Left inboard	C4161-3	C4158b-4	806 (PK/LB)
	C4161-4	C4158b-3	807 (PK/LG)
Right inboard	C4162-1	C4160b-4	802 (OG/RD)
	C4162-2	C4160b-3	803 (BN/PK)
Right outboard	C4162-3	C4159b-4	825

Yes
REPAIR the circuit in question. TEST the system for normal operation.

No
GO to [D11](#).

Yes
INSTALL a new rear subwoofer amplifier for the suspect amplifier. REFER to [Subwoofer Amplifier — Luggage Compartment](#) in this section. TEST the system for normal operation.

No
REPAIR the circuit in question. TEST the system for normal operation.

	C4162-4	C4159b-3	(TN/LG) 827 (TN/WH)
<ul style="list-style-type: none"> Is the resistance less than 5 ohms between the suspect rear subwoofer and the rear subwoofer amplifier, and greater than 10,000 ohms between the suspect rear subwoofer and ground? 			
D12 CHECK FOR CORRECT <u>ACM</u> OPERATION			
<ul style="list-style-type: none"> Disconnect all the <u>ACM</u> connectors. Check for: <ul style="list-style-type: none"> corrosion damaged pins pushed-out pins Connect all the <u>ACM</u> connectors and make sure they seat correctly. Operate the system and determine if the concern is still present. Is the concern still present? 			<p>Yes INSTALL a new <u>ACM</u>. REFER to Audio Control Module (ACM) in this section. TEST the system for normal operation.</p> <p>No The system is operating correctly at this time. The concern may have been caused by a loose or corroded connector.</p>

Pinpoint Test E: Loud Popping Sound When Cycling The Ignition Switch

Refer to Wiring Diagrams Cell [130](#), Audio System/Navigation for schematic and connector information.

Normal Operation

Voltage is supplied to the Audio Control Module (ACM) through circuit 1000 (RD/BK) when the ignition switch is turned to the START position. When the ACM receives this voltage, it mutes all speaker outputs and subwoofer amplifier enable circuits to eliminate the possibility of speaker pops during engine cranking.

This pinpoint test is intended to diagnose the following:

- Fuse
- Wiring, terminals or connectors
- Subwoofer amplifier
- ACM

PINPOINT TEST E: LOUD POPPING SOUND WHEN CYCLING THE IGNITION SWITCH

NOTICE: Use the correct probe adapter(s) when making measurements. Failure to use the correct probe adapter(s) may damage the connector.

Test Step	Result / Action to Take
E1 CHECK CIRCUIT 1000 (RD/BK) FOR VOLTAGE	
<ul style="list-style-type: none"> Ignition OFF. Disconnect: <u>ACM</u> C290d. Disconnect: Starter Relay. Hold the key in the START position. Measure the voltage between the <u>ACM</u> C290d-15 circuit 1000 (RD/BK), harness side and ground. 	<p>Yes GO to E2.</p> <p>No VERIFY the Smart Junction Box (SJB) fuse 20 (10A) is OK. If OK, REPAIR the circuit. TEST the system for normal operation. If not OK, REFER to the Wiring Diagrams Manual to identify the possible causes of the circuit short.</p>

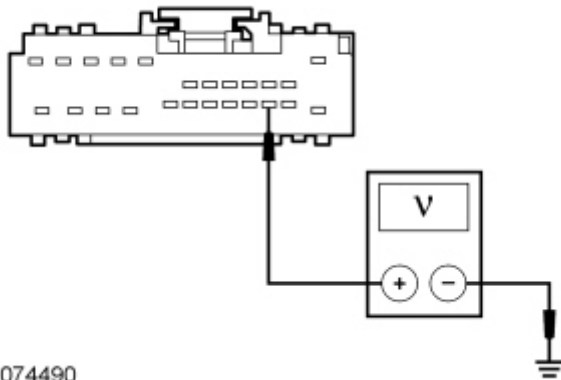

A0074490

- Is the voltage greater than 10 volts?

E2 ISOLATE THE FRONT/REAR SUBWOOFERS

NOTE: Repeat this step for each subwoofer amplifier.

- Ignition OFF.
- Connect: [ACM C290d](#).
- Disconnect: Suspect Subwoofer Amplifier.
- Cycle the key through all of the ignition switch positions.
- Is a loud popping sound present for only one subwoofer amplifier?

Yes

INSTALL a new subwoofer amplifier for the suspect subwoofer amplifier. REFER to [Subwoofer Amplifier — Door](#) or [Subwoofer Amplifier — Luggage Compartment](#) in this section. TEST the system for normal operation.

No

GO to [E3](#).

E3 CHECK FOR CORRECT [ACM](#) OPERATION

- Connect: Starter Relay.
- Disconnect all the [ACM](#) connectors.
- Check for:
 - corrosion
 - damaged pins
 - pushed-out pins
- Connect all the [ACM](#) connectors and make sure they seat correctly.
- Operate the system and determine if the concern is still present.
- Is the concern still present?

Yes

INSTALL a new [ACM](#). REFER to [Audio Control Module \(ACM\)](#) in this section. TEST the system for normal operation.

No

The system is operating correctly at this time. The concern may have been caused by a loose or corroded connector.

Pinpoint Test F: The Satellite Audio Is Inoperative/Does Not Operate Correctly

Refer to Wiring Diagrams Cell [130](#), Audio System/Navigation for schematic and connector information.

Normal Operation

The Satellite Digital Audio Receiver System (SDARS) module receives voltage through circuit 729 (RD/WH), and ground through circuit 1204 (BK/OG). Digital signals are received by the satellite antenna and sent to the [SDARS](#) module, which then provides audio signals to the Audio Control Module (ACM). The [SDARS](#) module and the [ACM](#) communicate using the Medium Speed Controller Area Network (MS-CAN) through circuits 1847 (WH/OG) and 1848 (PK/OG).

It is important to note that a concern in the satellite radio antenna may cause the satellite audio to be inoperative. However, if there is a concern with the satellite radio antenna, DTCs B1031 or B1032 should set. Make sure to verify the integrity of the satellite radio antenna and cable before carrying out this pinpoint test.

- DTC U0184 (Lost Communication With Radio [[ACM](#)]) — sets when the [SDARS](#) module is missing messages from the [ACM](#) for greater than 5 seconds. This results in loss of satellite radio functionality.
- DTC U0193 (Lost Communication With Digital Audio Control Module [[SDARS](#)]) — sets when the [ACM](#) is missing messages from the [SDARS](#) module for greater than 5 seconds. This results in loss of satellite radio functionality.

This pinpoint test is intended to diagnose the following:

- Subscription status
- Wiring, terminals or connectors
- [SDARS](#) module
- [ACM](#)

PINPOINT TEST F: THE SATELLITE AUDIO IS INOPERATIVE/DOES NOT OPERATE CORRECTLY

NOTICE: Use the correct probe adapter(s) when making measurements. Failure to use the correct probe adapter(s) may damage the connector.

Test Step	Result / Action to Take										
<p>F1 VERIFY AN ACTIVE SUBSCRIPTION</p> <ul style="list-style-type: none"> • Operate the audio system in satellite audio mode and observe the display. • Does the display read CALL SIRIUS? 	<p>Yes The subscription has expired. INFORM the customer to contact Sirius to re-activate the subscription.</p> <p>No GO to F2.</p>										
<p>F2 CHECK FOR SATELLITE AUDIO DTCs</p> <ul style="list-style-type: none"> • Clear the ACM and SDARS module DTCs. • Ignition OFF. • Ignition ON. • Wait 10 seconds. • Carry out the ACM and SDARS module self-tests. • Are any satellite audio system DTCs present? 	<p>Yes For DTC B1031 or DTC B1032 , GO to Pinpoint Test G .</p> <p>For DTC U0184 or U0193, GO to F3 .</p> <p>For all other DTCs, REFER to DTC Charts in this section.</p> <p>No GO to F3 .</p>										
<p>F3 CHECK THE SATELLITE AUDIO OUTPUT</p> <ul style="list-style-type: none"> • Enter the following diagnostic mode on the scan tool: Electrical->Audio->Tones Test->Satellite Digital Audio Receiver System. • Are alternating LH/RH tones audible? 	<p>Yes GO to F6 .</p> <p>No GO to F4 .</p>										
<p>F4 CHECK THE AUDIO CIRCUITS FROM THE SDARS MODULE FOR A SHORT TO VOLTAGE</p> <ul style="list-style-type: none"> • Ignition OFF. • Disconnect: ACM C290a. • Disconnect: SDARS Module C4344. • Ignition ON. • Measure the voltage between the SDARS module, harness side and ground as follows: <table border="1" data-bbox="220 1865 568 2094"> <thead> <tr> <th>Connector-Pin</th> <th>Circuit</th> </tr> </thead> <tbody> <tr> <td>C4344-5</td> <td>1595 (RD)</td> </tr> <tr> <td>C4344-6</td> <td>1597 (OG)</td> </tr> <tr> <td>C4344-11</td> <td>1594 (WH)</td> </tr> <tr> <td>C4344-12</td> <td>1596 (PK)</td> </tr> </tbody> </table>	Connector-Pin	Circuit	C4344-5	1595 (RD)	C4344-6	1597 (OG)	C4344-11	1594 (WH)	C4344-12	1596 (PK)	<p>Yes REPAIR the circuit in question. TEST the system for normal operation.</p> <p>No GO to F5 .</p>
Connector-Pin	Circuit										
C4344-5	1595 (RD)										
C4344-6	1597 (OG)										
C4344-11	1594 (WH)										
C4344-12	1596 (PK)										

<ul style="list-style-type: none"> • Is any voltage present? 																
F5 CHECK THE AUDIO CIRCUITS FROM THE <u>SDARS</u> MODULE FOR AN OPEN OR SHORT TO GROUND																
<ul style="list-style-type: none"> • Ignition OFF. • Measure the resistance between the <u>SDARS</u> module, harness side and the <u>ACM</u>, harness side; and between the <u>SDARS</u> module, harness side and ground as follows: <table border="1" data-bbox="220 409 975 786"> <thead> <tr> <th><u>SDARS</u> Module Connector-Pin</th> <th><u>ACM</u> Connector-Pin</th> <th>Circuit</th> </tr> </thead> <tbody> <tr> <td>C4344-5</td> <td>C290a-1</td> <td>1595 (RD or RD/WH)</td> </tr> <tr> <td>C4344-6</td> <td>C290a-9</td> <td>1597 (OG or OG/BK)</td> </tr> <tr> <td>C4344-11</td> <td>C290a-2</td> <td>1594 (WH or WH/BK)</td> </tr> <tr> <td>C4344-12</td> <td>C290a-10</td> <td>1596 (PK or PK/BK)</td> </tr> </tbody> </table> <ul style="list-style-type: none"> • Is the resistance less than 5 ohms between the <u>SDARS</u> module and the <u>ACM</u>, and greater than 10,000 ohms between the <u>SDARS</u> module and ground? 	<u>SDARS</u> Module Connector-Pin	<u>ACM</u> Connector-Pin	Circuit	C4344-5	C290a-1	1595 (RD or RD/WH)	C4344-6	C290a-9	1597 (OG or OG/BK)	C4344-11	C290a-2	1594 (WH or WH/BK)	C4344-12	C290a-10	1596 (PK or PK/BK)	<p>Yes GO to F6.</p> <p>No REPAIR the circuit in question. TEST the system for normal operation.</p>
<u>SDARS</u> Module Connector-Pin	<u>ACM</u> Connector-Pin	Circuit														
C4344-5	C290a-1	1595 (RD or RD/WH)														
C4344-6	C290a-9	1597 (OG or OG/BK)														
C4344-11	C290a-2	1594 (WH or WH/BK)														
C4344-12	C290a-10	1596 (PK or PK/BK)														
F6 ISOLATE THE <u>SDARS</u> MODULE																
<ul style="list-style-type: none"> • Connect: <u>ACM</u> C290a. • Install a new <u>SDARS</u> module. Refer to Satellite Digital Audio Receiver System (SDARS) Module in this section. • Operate the audio system in satellite audio mode. • Does the system operate correctly? 	<p>Yes The system is operating correctly at this time. The concern was caused by an inoperative <u>SDARS</u> module.</p> <p>No GO to F7.</p>															
F7 CHECK FOR CORRECT <u>ACM</u> OPERATION																
<ul style="list-style-type: none"> • Disconnect all the <u>ACM</u> connectors. • Check for: <ul style="list-style-type: none"> ■ corrosion ■ damaged pins ■ pushed-out pins • Connect all the <u>ACM</u> connectors and make sure they seat correctly. • Operate the system and determine if the concern is still present. • Is the concern still present? 	<p>Yes INSTALL a new <u>ACM</u>. REFER to Audio Control Module (ACM) in this section. TEST the system for normal operation.</p> <p>No The system is operating correctly at this time. The concern may have been caused by a loose or corroded connector.</p>															

Pinpoint Test G: Poor Reception/No Sound — Satellite Audio

Normal Operation

Digital signals are received by the satellite antenna and sent to the Satellite Digital Audio Receiver System (SDARS) module, which then converts the signals to analog and provides the audio signals to the Audio Control Module (ACM).

- DTC B1031 (SDARS Satellite Antenna Open) — sets when an open or high resistance is detected in the satellite antenna circuit. This DTC can be either continuous or on-demand.
- DTC B1032 (SDARS Satellite Antenna Short) — sets when a short to ground is detected in the satellite antenna circuit. This DTC can be either continuous or on-demand.

This pinpoint test is intended to diagnose the following:

- Obstructions to the line of sight
- Satellite radio antenna cable
- Satellite radio antenna
- [SDARS](#) module

PINPOINT TEST G: POOR RECEPTION/NO SOUND — SATELLITE AUDIO

NOTICE: Use the correct probe adapter(s) when making measurements. Failure to use the correct probe adapter(s) may damage the connector.

Test Step	Result / Action to Take
G1 REVIEW THE DTCs <ul style="list-style-type: none"> • Review the DTCs from the SDARS module self-test. • Is DTC B1031 or B1032 present? 	Yes GO to G3 . No GO to G2 .
G2 CHECK THE OPERATION OF THE SATELLITE AUDIO <ul style="list-style-type: none"> • Drive the vehicle to an open location, free of obstacles. • Operate the audio system in satellite audio mode. • Is the reception OK? 	Yes The system is OK at this time. ADVISE the customer that the satellite signal can be affected by obstructions to the satellite antenna line of sight. No GO to G3 .
G3 CHECK THE SATELLITE ANTENNA CABLE <ul style="list-style-type: none"> • Ignition OFF. • Disconnect: Satellite Antenna Connection (at SDARS Module). • Disconnect: Satellite Antenna Connection (at Satellite Antenna). • Measure the resistance of the satellite radio antenna cable between the SDARS module and the satellite antenna connection. • Is the resistance less than 1 ohm? 	Yes GO to G4 . No INSTALL a new satellite radio antenna cable. CLEAR the DTCs. REPEAT the self-test.
G4 ISOLATE THE SATELLITE ANTENNA <ul style="list-style-type: none"> • Install a new satellite antenna. Refer to Antenna — Satellite Radio in this section. • Operate the audio system in satellite audio mode. • Is the reception OK? 	Yes The system is operating correctly at this time. The concern was caused by an inoperative satellite radio antenna. CLEAR the DTCs. REPEAT the self-test. No INSTALL a new SDARS module. REFER to Satellite Digital Audio Receiver System (SDARS) Module in this section. TEST the system for normal operation.

Pinpoint Test H: No Global Positioning System (GPS) Antenna Signal

Normal Operation

The Global Positioning System (GPS) antenna provides information from the [GPS](#) satellite system to the [GPS](#) receiver in the Audio Control Module (ACM). This information is used to calculate vehicle position and direction of travel.

- DTC B2204 ([GPS](#) Antenna Connection Open or Short) — sets when an open, short to ground, or short to voltage is detected in the [GPS](#) antenna circuit. This DTC can be either continuous or on-demand.

This pinpoint test is intended to diagnose the following:

- [GPS](#) antenna
- [ACM](#)

PINPOINT TEST H: NO GLOBAL POSITIONING SYSTEM (GPS) ANTENNA SIGNAL

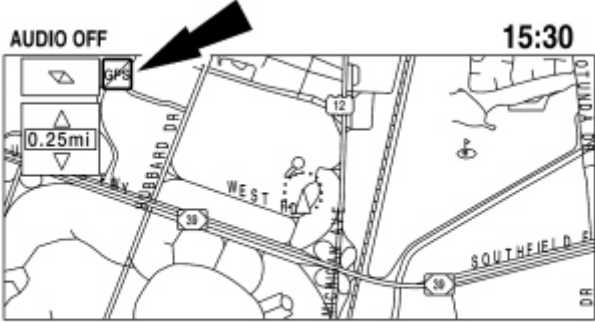
Test Step	Result / Action to Take
<p>H1 CHECK THE OPERATION OF THE GPS ICON</p> <ul style="list-style-type: none"> • Move the vehicle outside of any enclosed structure to an area that is unobstructed by trees, tall buildings, and bridges. • Operate the audio system in navigation mode.  <p>N0026638</p> <ul style="list-style-type: none"> • Does the GPS icon appear, then disappear? 	<p>Yes The system is operating correctly at this time. NOTIFY the customer that obstructions to the line of sight may affect the GPS antenna.</p> <p>No GO to H2.</p>
<p>H2 CHECK THE ACM RECORDED DTCs</p> <ul style="list-style-type: none"> • Check the recorded DTCs from the ACM self-test. • Is DTC B2204 recorded? 	<p>Yes GO to H4.</p> <p>No GO to H3.</p>
<p>H3 CHECK THE GPS ANTENNA MOUNTING</p> <ul style="list-style-type: none"> • Verify the GPS antenna is installed correctly and no aftermarket equipment is obstructing it. • Is the GPS antenna mounted correctly? 	<p>Yes GO to H4.</p> <p>No Correctly INSTALL the GPS antenna. REFER to Global Positioning System (GPS) Antenna in this section. TEST the system for normal operation.</p>
<p>H4 ISOLATE THE GPS ANTENNA</p> <ul style="list-style-type: none"> • Install a new GPS antenna. Refer to Global Positioning System (GPS) Antenna in this section. • Move the vehicle outside of any enclosed structure to an area that is unobstructed by trees, tall buildings, and bridges. • Operate the audio system in navigation mode. 	<p>Yes The system is operating correctly at this time. The concern was caused by an inoperative GPS antenna. CLEAR the DTCs. REPEAT the self-test.</p> <p>No GO to H5.</p>

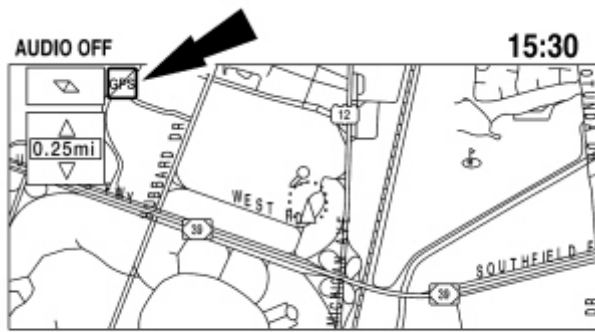

N0026638

- Does the **GPS** icon appear, then disappear?

H5 CHECK FOR CORRECT **ACM** OPERATION

- Disconnect all the **ACM** connectors.
- Check for:
 - corrosion
 - damaged pins
 - pushed-out pins
- Connect all the **ACM** connectors and make sure they seat correctly.
- Operate the system and verify the concern is still present.
- **Is the concern still present?**

Yes

INSTALL a new **ACM**. REFER to [Audio Control Module \(ACM\)](#) in this section. TEST the system for normal operation.

No

The system is operating correctly at this time. The concern may have been caused by a loose or corroded connector. CLEAR the DTCs. REPEAT the self-test.

Pinpoint Test I: The Audible Switch Feedback Is Inoperative

Normal Operation

The audible switch feedback settings are controlled by the Audio Control Module (ACM). The audible switch feedback can be set to ALL, TOUCH SCREEN, or NONE, depending on user preference.

This pinpoint test is intended to diagnose the following:

- Audible switch feedback setting
- **ACM**

PINPOINT TEST I: THE AUDIBLE SWITCH FEEDBACK IS INOPERATIVE

Test Step	Result / Action to Take
I1 CHECK THE SWITCH DISPLAY	
<ul style="list-style-type: none"> • Ignition ON. • Turn the ACM on. • Press the MENU button. • Select the FEEDBACK tab. 	<p>Yes SELECT ALL BUTTONS. TEST the system for normal operation.</p> <p>No GO to I2.</p>

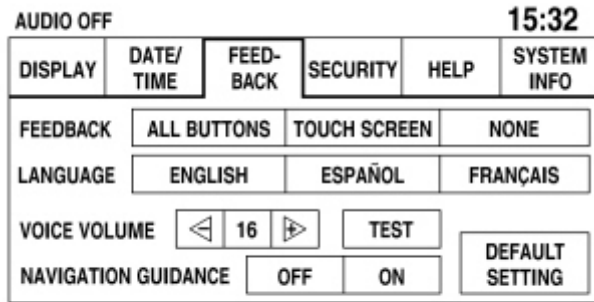

N0026637

- Is **NONE** highlighted on the audible feedback settings?

I2 CHECK FOR CORRECT [ACM](#) OPERATION

- Disconnect all the [ACM](#) connectors.
- Check for:
 - corrosion
 - damaged pins
 - pushed-out pins
- Connect all the [ACM](#) connectors and make sure they seat correctly.
- Operate the system and verify the concern is still present.
- **Is the concern still present?**

Yes
 INSTALL a new [ACM](#). REFER to [Audio Control Module \(ACM\)](#) in this section.
 TEST the system for normal operation.

No
 The system is operating correctly at this time. The concern may have been caused by a loose or corroded connector. CLEAR the DTCs. REPEAT the self-test.

Pinpoint Test J: The Voice Guidance Is Inoperative/Does Not Operate Correctly

Normal Operation

The voice guidance settings are controlled by the Audio Control Module (ACM). The voice guidance volume can be adjusted or turned off depending on user preference.

This pinpoint test is intended to diagnose the following:

- Incorrect system setting
- [ACM](#)

PINPOINT TEST J: THE VOICE GUIDANCE IS INOPERATIVE/DOES NOT OPERATE CORRECTLY

Test Step	Result / Action to Take
<p>J1 CHECK THE VOICE GUIDANCE SETTINGS</p>	
<ul style="list-style-type: none"> • Ignition ON. • Turn the ACM on. • Press the MENU button. • Select the FEEDBACK tab. 	<p>Yes The system is operating correctly at this time.</p> <p>No GO to J2.</p>

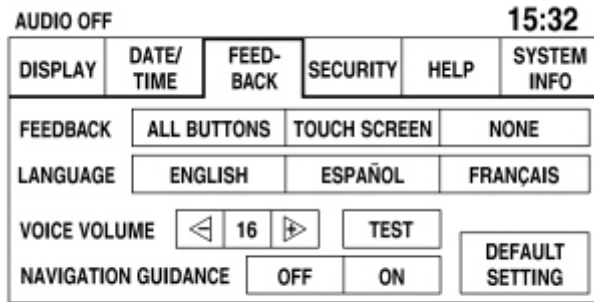

N0026637

- Select DEFAULT SETTING.
- Verify the voice guidance operation.
- **Does the voice guidance operate correctly?**

J2 CHECK FOR CORRECT ACM OPERATION

- Disconnect all the ACM connectors.
- Check for:
 - corrosion
 - damaged pins
 - pushed-out pins
- Connect all the ACM connectors and make sure they seat correctly.
- Operate the system and verify the concern is still present.
- **Is the concern still present?**

Yes

INSTALL a new ACM. REFER to [Audio Control Module \(ACM\)](#) in this section. TEST the system for normal operation.

No

The system is operating correctly at this time. The concern may have been caused by a loose or corroded connector. CLEAR the DTCs. REPEAT the self-test.

Pinpoint Test K: DTC B2924

Normal Operation

This DTC sets as a continuous DTC when an Audio Control Module (ACM) button is detected as active for greater than 120 seconds, or sets on-demand if a button is detected as active for greater than 3 seconds during the self-test.

This pinpoint test is intended to diagnose the following:

- ACM

PINPOINT TEST K: DTC B2924

Test Step	Result / Action to Take
K1 CHECK FOR STUCK <u>ACM</u> BUTTONS	
<ul style="list-style-type: none"> • Operate the audio system in radio tuner (AM/FM) mode. • Enter the self-diagnostic menu and select the HARDKEY TEST function. • NOTE: If any button is pushed, the corresponding button on the screen appears highlighted. • Observe the buttons on the screen. 	<p>Yes GO to K2.</p> <p>No The system is operating correctly at this time.</p>

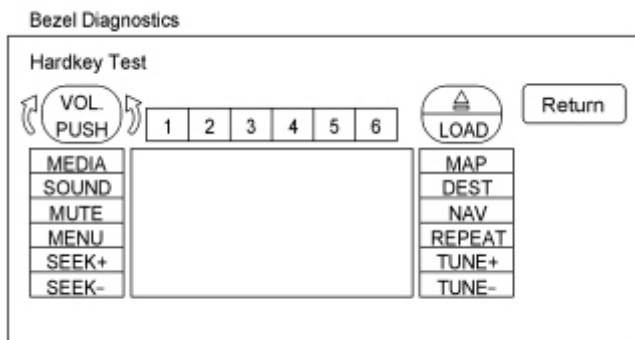

N0027403

- Does the hardkey test indicate a stuck button?

K2 CHECK FOR CORRECT [ACM](#) OPERATION

- Disconnect all the [ACM](#) connectors.
- Check for:
 - corrosion
 - damaged pins
 - pushed-out pins
- Connect all the [ACM](#) connectors and make sure they seat correctly.
- Operate the system and verify the concern is still present.
- **Is the concern still present?**

Yes

INSTALL a new [ACM](#). REFER to [Audio Control Module \(ACM\)](#) in this section. TEST the system for normal operation.

No

The system is operating correctly at this time. The concern may have been caused by a loose or corroded connector. CLEAR the DTCs. REPEAT the self-test.

Pinpoint Test L: The Position Cursor Is Inaccurate

Normal Operation

The primary source of vehicle location for the navigation system is the Audio Control Module (ACM) receiving the position signal through the Global Positioning System (GPS) antenna.

In addition, the [ACM](#) receives the navigation rolling wheel count signal from the Instrument Cluster (IC) (which gateways the signal from the ABS module). This secondary signal is used to calculate vehicle position when the [GPS](#) signal is lost. It also supports the adaptive learning function of the [ACM](#), whereby the [ACM](#) can compensate for long-term differences between the [GPS](#) signal location, and the actual distance traveled by the vehicle.

- DTC B2204 ([GPS](#) Antenna Connection Open or Short) — sets when an open, short to ground, or short to voltage is detected in the [GPS](#) antenna circuit. If DTC B2204 is present, [GO to Pinpoint Test H](#) .
- DTC U0155 (Lost Communication With Instrument Panel Cluster [[IC](#)] Control Module) — sets when the navigation rolling wheel count signal is lost for greater than 5 seconds. When the signal is lost, DTC U2473 should also be set. If no symptoms are present and DTC U2473 is not present, this DTC can be ignored, as it may have been set by a low battery voltage condition.
- DTC U2473 (Unexpected Vehicle Speed) — sets when the calculated vehicle distance traveled based on the navigation rolling wheel count signal does not agree with the [GPS](#) antenna location. To do this, the [ACM](#) monitors the navigation rolling wheel count signal during a 4-second range, and compares it with the change in [GPS](#) antenna location. If the [ACM](#) finds that the variation is greater than 0.5% after carrying out this check 4 times, it sets DTC U2473.

This pinpoint test is intended to diagnose the following:

- Vehicle Speed Sensor (VSS) signal concern
- [ACM](#)

PINPOINT TEST L: THE POSITION CURSOR IS INACCURATE

Test Step	Result / Action to Take
L1 CHECK THE ACM DTCs	
<ul style="list-style-type: none"> Review the DTCs from the ACM self-test. Is DTC U2473 present? 	<p>Yes GO to L2.</p> <p>No GO to Pinpoint Test H.</p>
L2 CHECK THE IC AND ABS MODULE DTCs	
<ul style="list-style-type: none"> Carry out the self-test for the IC and the ABS module. Are any DTCs recorded? 	<p>Yes REFER to Section 413-01 (IC) or Section 206-09 (ABS module) to diagnose a fault in the navigation rolling wheel count signal.</p> <p>No GO to L3.</p>
L3 CHECK FOR CORRECT ACM OPERATION	
<ul style="list-style-type: none"> Disconnect all the ACM connectors. Check for: <ul style="list-style-type: none"> corrosion damaged pins pushed-out pins Connect all the ACM connectors and make sure they seat correctly. Operate the system and verify the concern is still present. Is the concern still present? 	<p>Yes INSTALL a new ACM. REFER to Audio Control Module (ACM) in this section. TEST the system for normal operation.</p> <p>No The system is operating correctly at this time. The concern may have been caused by a loose or corroded connector. CLEAR the DTCs. REPEAT the self-test.</p>

Pinpoint Test M: The Speed Sensitive Volume Does Not Operate Correctly

Normal Operation

The speed sensitive volume function adjusts the volume based on the Vehicle Speed Sensor (VSS) signal from the Instrument Cluster (IC). The [IC](#) does not generate the [VSS](#) signal, it gateways the signal from the PCM.

- DTC U0155 (Lost Communication With Instrument Panel Cluster [[IC](#)] Control Module) — sets when the [VSS](#) signal is lost for greater than 5 seconds. When the signal is lost, the Audio Control Module (ACM) turns the speed sensitive volume feature off. The Smart Junction Box (SJB) also receives this signal, and should demonstrate symptoms if the [VSS](#) signal is lost. If no symptoms are present, this DTC can be ignored, as it may have been set by a low battery voltage condition.

This pinpoint test is intended to diagnose the following:

- Speed sensitive volume setting
- [VSS](#) signal concern
- [ACM](#)

PINPOINT TEST M: THE SPEED SENSITIVE VOLUME DOES NOT OPERATE CORRECTLY

Test Step	Result / Action to Take
M1 CHECK THE SPEEDOMETER OPERATION	
<ul style="list-style-type: none"> Drive the vehicle and observe the speedometer. Does the speedometer operate correctly? 	<p>Yes GO to M2.</p> <p>No</p>

	REFER to Section 413-01 .
M2 CHECK THE SPEED SENSITIVE VOLUME SETTING	
<ul style="list-style-type: none"> • Turn the speed sensitive volume off. Refer to the Owner's Literature. • Operate the audio system in radio tuner (AM/FM) mode. • Drive the vehicle at various speeds and observe the speaker volume. • Set the speed sensitive volume to maximum compensation. Refer to the Owner's Literature. • Operate the audio system in radio tuner (AM/FM) mode. • Drive the vehicle at various speeds and observe the speaker volume. • Does the volume remain constant with the speed sensitive volume turned off, and increase and decrease with vehicle speed with the speed sensitive volume set to maximum? 	<p>Yes The system is operating correctly at this time. INFORM the customer of the correct operation.</p> <p>No GO to M3.</p>
M3 CHECK FOR DTC U0155	
<ul style="list-style-type: none"> • Ignition OFF. • Clear the SJB and ACM DTCs. • Ignition ON. • Wait 10 seconds, and re-run the ACM self-test. • Run the SJB self-test. • Is DTC U0155 present in both the ACM and the SJB ? 	<p>Yes GO to M5.</p> <p>No GO to M4.</p>
M4 CHECK FOR CORRECT ACM OPERATION	
<ul style="list-style-type: none"> • Disconnect all the ACM connectors. • Check for: <ul style="list-style-type: none"> ■ corrosion ■ damaged pins ■ pushed-out pins • Connect all the ACM connectors and make sure they seat correctly. • Operate the system and determine if the concern is still present. • Is the concern still present? 	<p>Yes INSTALL a new ACM. REFER to Audio Control Module (ACM) in this section. TEST the system for normal operation.</p> <p>No The system is operating correctly at this time. The concern may have been caused by a loose or corroded connector. CLEAR the DTCs. REPEAT the self-test.</p>
M5 CHECK FOR CORRECT IC OPERATION	
<ul style="list-style-type: none"> • Disconnect the IC connector. • Check for: <ul style="list-style-type: none"> ■ corrosion ■ damaged pins ■ pushed-out pins • Connect the IC connector and make sure it seats correctly. • Operate the system and determine if the concern is still present. • Is the concern still present? 	<p>Yes INSTALL a new IC. REFER to Section 413-01. CLEAR the ACM DTCs. TEST the system for normal operation.</p> <p>No The system is operating correctly at this time. The concern may have been caused by a loose or corroded connector. CLEAR the DTCs. REPEAT the self-test.</p>

Pinpoint Test N: The Audio Input Jack Is Inoperative/Does Not Operate Correctly

Refer to Wiring Diagrams Cell [130](#), Audio System/Navigation for schematic and connector information.

Normal Operation

Audio signals are sent from the audio input jack to the Audio Control Module (ACM). There are no external power or ground circuits to the audio input jack.

This pinpoint test is intended to diagnose the following:

- Wiring, terminals or connectors

- Audio input jack
- [ACM](#)

PINPOINT TEST N: THE AUDIO INPUT JACK IS INOPERATIVE/DOES NOT OPERATE CORRECTLY

NOTICE: Use the correct probe adapter(s) when making measurements. Failure to use the correct probe adapter(s) may damage the connector.

NOTE: Before carrying out this pinpoint test, be sure the MP3 device is operating correctly.

Test Step	Result / Action to Take															
<p>N1 CHECK THE AUDIO INPUT JACK AUDIO</p> <ul style="list-style-type: none"> • Connect: Known Good MP3 Device (To Audio Input Jack). • Using the known good device, attempt to play an audio file. • Does the audio file play correctly? 	<p>Yes The system is operating correctly at this time. The concern may be with the customer device.</p> <p>No GO to N2.</p>															
<p>N2 CHECK THE AUDIO INPUT JACK CIRCUITS FOR A SHORT TO VOLTAGE</p> <ul style="list-style-type: none"> • Ignition OFF. • Disconnect: Audio Input Jack C3312. • Ignition ON. • Measure the voltage between the audio input jack, harness side and ground as follows: <table border="1" data-bbox="220 1111 839 1341"> <thead> <tr> <th>Audio Input Jack Connector-Pin</th> <th>Circuit</th> </tr> </thead> <tbody> <tr> <td>C3312-1</td> <td>2048 (RD/BK)</td> </tr> <tr> <td>C3312-2</td> <td>2047 (RD/WH)</td> </tr> <tr> <td>C3312-3</td> <td>2049 (DG/WH)</td> </tr> <tr> <td>C3312-4</td> <td>2050 (LG/BK)</td> </tr> </tbody> </table> <ul style="list-style-type: none"> • Is any voltage present? 	Audio Input Jack Connector-Pin	Circuit	C3312-1	2048 (RD/BK)	C3312-2	2047 (RD/WH)	C3312-3	2049 (DG/WH)	C3312-4	2050 (LG/BK)	<p>Yes REPAIR the circuit in question. TEST the system for normal operation.</p> <p>No GO to N3.</p>					
Audio Input Jack Connector-Pin	Circuit															
C3312-1	2048 (RD/BK)															
C3312-2	2047 (RD/WH)															
C3312-3	2049 (DG/WH)															
C3312-4	2050 (LG/BK)															
<p>N3 CHECK THE AUDIO INPUT JACK CIRCUITS FOR AN OPEN OR SHORT TO GROUND</p> <ul style="list-style-type: none"> • Ignition OFF. • Disconnect: ACM C290a. • Measure the resistance between the audio input jack, harness side and the ACM, harness side; and between the audio input jack, harness side and ground as follows: <table border="1" data-bbox="220 1671 987 2047"> <thead> <tr> <th>Audio Input Jack Connector-Pin</th> <th>ACM Connector-Pin</th> <th>Circuit</th> </tr> </thead> <tbody> <tr> <td>C3312-1</td> <td>C290a-6</td> <td>2048 (RD/BK)</td> </tr> <tr> <td>C3312-2</td> <td>C290a-14</td> <td>2047 (RD/WH)</td> </tr> <tr> <td>C3312-3</td> <td>C290a-8</td> <td>2049 (LG/WH)</td> </tr> <tr> <td>C3312-4</td> <td>C290a-7</td> <td>2050 (LG/BK)</td> </tr> </tbody> </table> <ul style="list-style-type: none"> • Is the resistance less than 5 ohms between the audio input 	Audio Input Jack Connector-Pin	ACM Connector-Pin	Circuit	C3312-1	C290a-6	2048 (RD/BK)	C3312-2	C290a-14	2047 (RD/WH)	C3312-3	C290a-8	2049 (LG/WH)	C3312-4	C290a-7	2050 (LG/BK)	<p>Yes GO to N4.</p> <p>No REPAIR the circuit in question. TEST the system for normal operation.</p>
Audio Input Jack Connector-Pin	ACM Connector-Pin	Circuit														
C3312-1	C290a-6	2048 (RD/BK)														
C3312-2	C290a-14	2047 (RD/WH)														
C3312-3	C290a-8	2049 (LG/WH)														
C3312-4	C290a-7	2050 (LG/BK)														

jack and the ACM , and greater than 10,000 ohms between the audio input jack and ground?	
N4 ISOLATE THE AUDIO INPUT JACK	
<ul style="list-style-type: none"> ● Install a new audio input jack. ● Connect: Known Good MP3 Device (To Audio Input Jack). ● Using the known good device, attempt to play an audio file. ● Does the audio file play correctly? 	<p>Yes The system is operating correctly at this time. The concern was caused by an inoperative audio input jack.</p> <p>No GO to N5.</p>
N5 CHECK FOR CORRECT ACM OPERATION	
<ul style="list-style-type: none"> ● Disconnect all the ACM connectors. ● Check for: <ul style="list-style-type: none"> ■ corrosion ■ damaged pins ■ pushed-out pins ● Connect all the ACM connectors and make sure they seat correctly. ● Operate the system and determine if the concern is still present. ● Is the concern still present? 	<p>Yes INSTALL a new ACM. REFER to Audio Control Module (ACM) in this section. TEST the system for normal operation.</p> <p>No The system is operating correctly at this time. The concern may have been caused by a loose or corroded connector.</p>

Pinpoint Test O: DTC B1318

Refer to Wiring Diagrams Cell [130](#), Audio System/Navigation for schematic and connector information.

Normal Operation

- DTC B1318 (Battery Voltage Low) — set by the Audio Control Module (ACM) as a continuous DTC if the **ACM** detects low battery voltage below 10 volts for greater than 10 seconds on circuit 729 (RD/WH). The **ACM** does not check the circuit for voltage with the key in START.

This pinpoint test is intended to diagnose the following:

- Wiring, terminals or connectors
- High circuit resistance
- **ACM**

PINPOINT TEST O: DTC B1318

NOTICE: Use the correct probe adapter(s) when making measurements. Failure to use the correct probe adapter(s) may damage the connector.

NOTE: Failure to disconnect the battery when instructed will result in false resistance readings. Refer to [Section 414-01](#).

Test Step	Result / Action to Take
O1 RECHECK THE ACM DTCs	
<ul style="list-style-type: none"> ● Clear the ACM DTCs. ● Ignition OFF. ● Ignition ON. ● Wait 10 seconds. ● Repeat the ACM self-test. ● Is DTC B1318 still present? 	<p>Yes GO to O2.</p> <p>No The system is operating correctly at this time. The DTC may have been set due to a previous low battery voltage condition.</p>

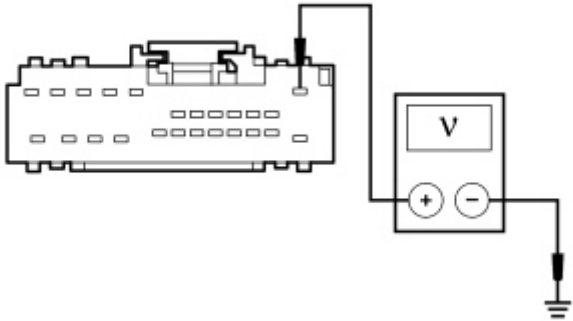
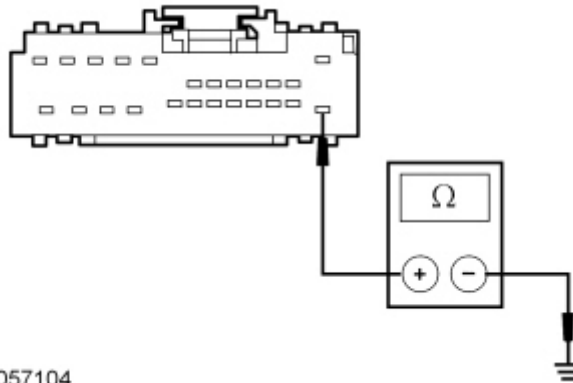
O2 CHECK FOR CHARGING SYSTEM DTCs IN THE PCM	<p>Yes REFER to Section 414-00.</p> <p>No GO to O3.</p>
O3 CHECK THE BATTERY CONDITION AND STATE OF CHARGE	<p>Yes GO to O4.</p> <p>No REFER to Section 414-01.</p>
<ul style="list-style-type: none"> • Carry out the PCM self-test. • Is DTC P0620, P0622, P0625, P0626 or P0656 set in the PCM? 	
O4 CHECK THE ACM VOLTAGE SUPPLY	<p>Yes GO to O5.</p> <p>No REPAIR the circuit for high resistance. CLEAR the DTC. REPEAT the self-test.</p>
<ul style="list-style-type: none"> • Ignition OFF. • Measure and record the voltage at the battery. • Disconnect: ACM C290d. • Ignition ON. • Measure the voltage between the ACM C290d-1, circuit 729 (RD/WH), harness side and ground.  <p>N0082032</p> <ul style="list-style-type: none"> • Is the voltage within 0.2 volt of the recorded battery voltage? 	
O5 CHECK THE ACM GROUND CIRCUIT	<p>Yes GO to O6.</p> <p>No REPAIR the circuit for high resistance. TEST the system for normal operation.</p>
<ul style="list-style-type: none"> • Ignition OFF. • Disconnect: Negative Battery Cable. • Measure the resistance between the ACM C290d-13, circuit 1204 (BK/OG), harness side and ground.  <p>A0057104</p> <ul style="list-style-type: none"> • Is the resistance less than 5 ohms? 	
O6 CHECK FOR CORRECT ACM OPERATION	<p>Yes INSTALL a new ACM. REFER to Audio Control Module (ACM). TEST the system for normal</p>
<ul style="list-style-type: none"> • Disconnect all the ACM connectors. • Check for: <ul style="list-style-type: none"> ■ corrosion ■ damaged pins 	

- pushed-out pins
- Connect all the [ACM](#) connectors and make sure they seat correctly.
- Operate the system and determine if the concern is still present.
- **Is the concern still present?**

operation.

No

The system is operating correctly at this time. The concern may have been caused by a loose or corroded connector.

Pinpoint Test P: DTC B1318

Refer to Wiring Diagrams Cell [130](#), Audio System/Navigation for schematic and connector information.

Normal Operation

- DTC B1318 (Battery Voltage Low) — set by the Satellite Digital Audio Receiver System (SDARS) module as a continuous DTC if the [SDARS](#) module detects low battery voltage below 10 volts for greater than 10 seconds on circuit 729 (RD/WH). The [SDARS](#) module does not check the circuit for voltage with the key in START.

This pinpoint test is intended to diagnose the following:

- Wiring, terminals or connectors
- High circuit resistance
- [SDARS](#) module

PINPOINT TEST P: DTC B1318

NOTICE: Use the correct probe adapter(s) when making measurements. Failure to use the correct probe adapter(s) may damage the connector.

NOTE: Failure to disconnect the battery when instructed will result in false resistance readings. Refer to [Section 414-01](#).

Test Step	Result / Action to Take
P1 RECHECK THE SDARS MODULE DTCs	
<ul style="list-style-type: none"> ● Clear the SDARS module DTCs. ● Ignition OFF. ● Ignition ON. ● Wait 10 seconds. ● Repeat the SDARS module self-test. ● Is DTC B1318 still present? 	<p>Yes GO to P2.</p> <p>No The system is operating correctly at this time. The DTC may have been set due to a previous low battery voltage condition.</p>
P2 CHECK FOR CHARGING SYSTEM DTCs IN THE PCM	
<ul style="list-style-type: none"> ● Carry out the PCM self-test. ● Is DTC P0620, P0622, P0625, P0626 or P0656 set in the PCM? 	<p>Yes REFER to Section 414-00.</p> <p>No GO to P3.</p>
P3 CHECK THE BATTERY CONDITION AND STATE OF CHARGE	
<ul style="list-style-type: none"> ● Check the battery condition and verify that the battery is fully charged. Refer to Section 414-01. ● Is the battery OK and fully charged? 	<p>Yes GO to P4.</p> <p>No REFER to Section 414-01.</p>
P4 CHECK THE SDARS MODULE VOLTAGE SUPPLY	
<ul style="list-style-type: none"> ● Ignition OFF. ● Measure and record the voltage at the battery. 	<p>Yes GO to P5.</p>

- Disconnect: [SDARS](#) Module C4344.
- Ignition ON.
- Measure the voltage between the [SDARS](#) module C4344-9, circuit 729 (RD/WH), harness side and ground.

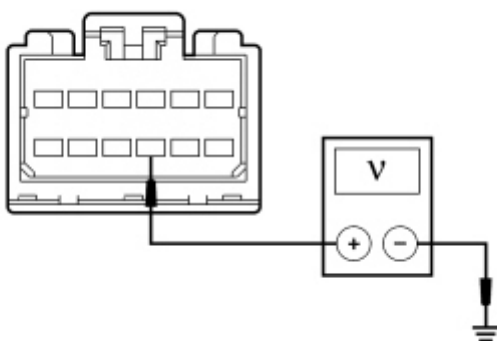

N0082033

- Is the voltage within 0.2 volt of the recorded battery voltage?

No
REPAIR the circuit for high resistance. CLEAR the DTC. REPEAT the self-test.

P5 CHECK THE [SDARS](#) MODULE GROUND CIRCUIT

- Ignition OFF.
- Disconnect: Negative Battery Cable.
- Measure the resistance between the [SDARS](#) module C4344-3, circuit 1204 (BK/OG), harness side and ground.

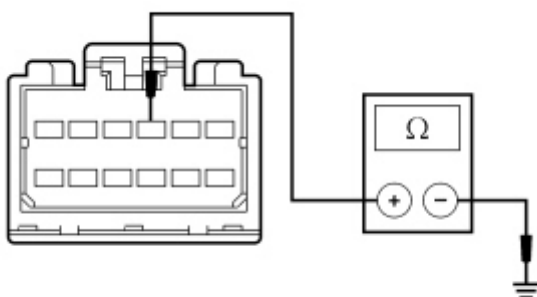

N0082034

- Is the resistance less than 5 ohms?

Yes
GO to [P6](#).

No
REPAIR the circuit for high resistance. TEST the system for normal operation.

P6 CHECK FOR CORRECT [SDARS](#) MODULE OPERATION

- Disconnect the [SDARS](#) module connector.
- Check for:
 - corrosion
 - damaged pins
 - pushed-out pins
- Connect the [SDARS](#) module connector and make sure it seats correctly.
- Operate the system and determine if the concern is still present.
- Is the concern still present?

Yes
INSTALL a new [SDARS](#) module. REFER to [Satellite Digital Audio Receiver System \(SDARS\) Module](#). TEST the system for normal operation.

No
The system is operating correctly at this time. The concern may have been caused by a loose or corroded connector.

Pinpoint Test Q: DTC U0140

Normal Operation

- DTC U0140 (Lost Communication With Body Control Module [[GEM](#)]) — set by the Audio Control Module (ACM) if the illumination dimmer level message is not received from the Smart Junction Box (SJB) over the Medium Speed Controller Area Network (MS-CAN) for greater than 5 seconds. The [SJB](#) also sends

this signal to other modules with network-based illumination. Those other modules should also exhibit incorrect illumination operation if the illumination dimmer level signal is missing.

This pinpoint test is intended to diagnose the following:

- Module communication
- [SJB](#)
- [ACM](#)

PINPOINT TEST Q: DTC U0140

Test Step	Result / Action to Take
<p>Q1 VERIFY THE OPERATION OF THE PANEL ILLUMINATION</p>	<p>Yes The system is operating correctly at this time. The DTC may have been set due to high network traffic or intermittent fault condition.</p> <p>No GO to Q2.</p>
<ul style="list-style-type: none"> • Ignition ON. • Turn the parking lamps on. • Cycle the dimmer switch through all positions. • Does the panel illumination operate correctly for all components with network-based illumination (including the ACM)? 	
<p>Q2 CHECK THE COMMUNICATION NETWORK</p>	<p>Yes GO to Q3.</p> <p>No REFER to Section 418-00.</p>
<ul style="list-style-type: none"> • Turn the parking lamps off. • Carry out the network test using the scan tool. • Does the SJB pass the network test? 	
<p>Q3 RETRIEVE THE RECORDED DTCs FROM THE ACM SELF-TEST</p>	<p>Yes GO to Pinpoint Test O.</p> <p>No GO to Q4.</p>
<ul style="list-style-type: none"> • Check for recorded ACM DTCs from the self-test. • Is DTC B1318 recorded? 	
<p>Q4 RECHECK THE ACM DTCs</p>	<p>Yes GO to Q5.</p> <p>No The system is operating correctly at this time. The DTC may have been set due to high network traffic.</p>
<p>NOTE: If new modules were installed prior to the DTC being set, the module configuration may be incorrectly set during Programmable Module Installation (PMI) or the PMI may not have been carried out.</p> <ul style="list-style-type: none"> • Clear the ACM continuous DTCs. • Ignition OFF. • Ignition ON. • Wait 10 seconds. • Retrieve the ACM continuous DTCs. • Is DTC U0140 still present? 	
<p>Q5 CHECK FOR DTC U0140 SET IN OTHER MODULES</p>	<p>Yes INSTALL a new SJB. REFER to Section 419-10. CLEAR the ACM DTCs. REPEAT the self-test.</p> <p>No INSTALL a new ACM. REFER to Audio Control Module (ACM) in this section. TEST the system for normal operation.</p>
<ul style="list-style-type: none"> • Clear all DTCs from all modules. • Ignition OFF. • Ignition ON. • Wait 10 seconds. • Retrieve the continuous memory DTCs from all modules. • Is DTC U0140 set in any modules other than the ACM ? 	

Pinpoint Test R: The Display Screen Is Inoperative

Normal Operation

The display screen shows all of the audio system information, including radio tuner (AM/FM), navigation, and satellite radio information (if equipped). The display is completely controlled by the Audio Control Module (ACM).

This pinpoint test is intended to diagnose the following:

- Audio system concern
- [ACM](#)

PINPOINT TEST R: THE DISPLAY SCREEN IS INOPERATIVE

Test Step	Result / Action to Take
R1 VERIFY THE OPERATION OF THE RADIO TUNER SYSTEM	
<ul style="list-style-type: none">• Ignition ON.• Operate the audio system in radio tuner (AM/FM) mode.• Does the audio system operate correctly in radio tuner (AM/FM) mode?	<p>Yes GO to R2.</p> <p>No GO to Symptom Chart - Navigation.</p>
R2 CHECK FOR CORRECT ACM OPERATION	
<ul style="list-style-type: none">• Ignition OFF.• Disconnect all the ACM connectors.• Check for:<ul style="list-style-type: none">▪ corrosion▪ damaged pins▪ pushed-out pins• Connect the ACM connectors and make sure they seat correctly.• Operate the system and determine if the concern is still present.• Is the concern still present?	<p>Yes INSTALL a new ACM. REFER to Audio Control Module (ACM) in this section. TEST the system for normal operation.</p> <p>No The system is operating correctly at this time. The concern may have been caused by a loose or corroded connector.</p>